

Introduction

This series of product is a module design of inverter and built-in MPPT controller, which has the advantages of high conversion efficiency, low power consumption and strong load-carrying ability. With intelligent control, customers can set charging mode, (Utility as complementary power) AC first mode or DC first mode, timed inversion mode and timed utility mode, timed on/off sleep mode. This is the currently the most advanced inverter & controller hybrid in the world.

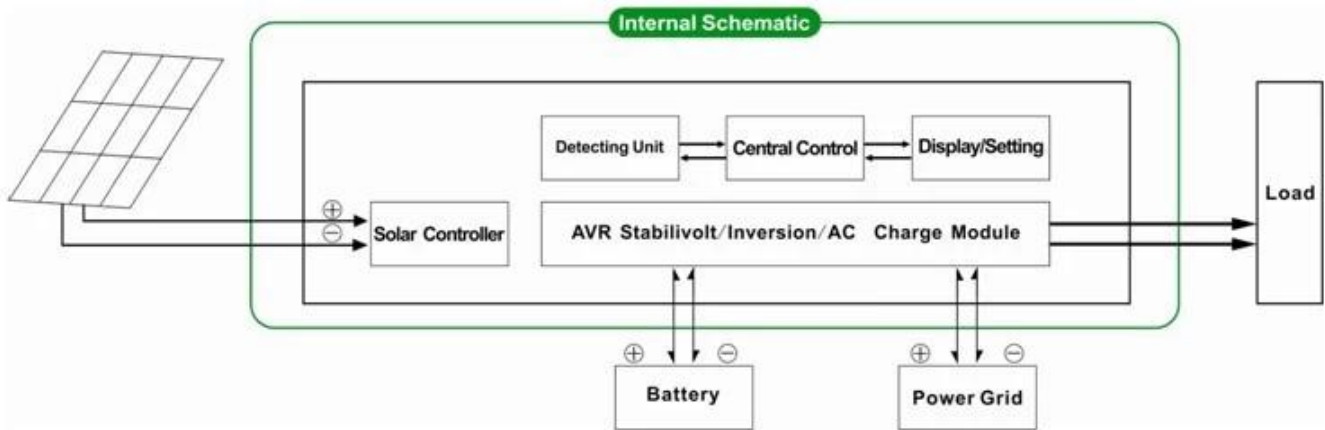

Feature

1. Easy to install. To configure a solar system, customers only need to connect it with solar panels and batteries
2. CPU management ,intelligent control,modular design, User-friendly LCD display
3. Built-in MPPT controller, high charging efficiency
4. Low power consumption, high conversion efficiency
5. Intellectual,multi-function, convenient for customers with different using environment to fully use the solar energy
6. External battery connection, convenient to expand back-up power time
7. Strong load-carrying ability, low failure rate, easy maintenance and long service life (under proper operation, it may be as long as 5 years)
8. Perfect protection: low voltage protection, over voltage protection, overheat protection, short-circuit protection, overloads protection
9. CE / EMC / LVD/ RoHS Approvals
10. Two years warranty, life-long technical supports

Function

- 1.Charging function

There are 2 modes as shown bellow:



1.1 PV charge the battery, utility will not: when PV and utility are both connected to the machine, only the PV will charge the battery when there is sunlight

1.2 Both PV and utility will charge the battery: when PV and utility are both connected to the machine, AC (utility) will charge the battery. In the meanwhile, PV will also charge the battery if there is sunlight.

2. Utility as complementary power function

There are 2 kinds of complementary modes, shown as bellow:



2.1 AC first , DC standby UPS mode

When both utility and battery are connected to the machine, utility will supply power to the loads prior to the battery. When utility is cut off, the battery will automatically continue to supply power.

Steps are as follows:

Step 1: When utility power is available, it will output directly after voltage being stabilized and charge batteries at the same time.

Step 2: When utility power is cut off suddenly, the inverter will convert DC power to AC power automatically to ensure uninterrupted power supply within 5ms.

Step 3: When utility power becomes available again, it will automatically transfer to utility supplying power to loads and charge batteries at the same time.

See Workflow as below:

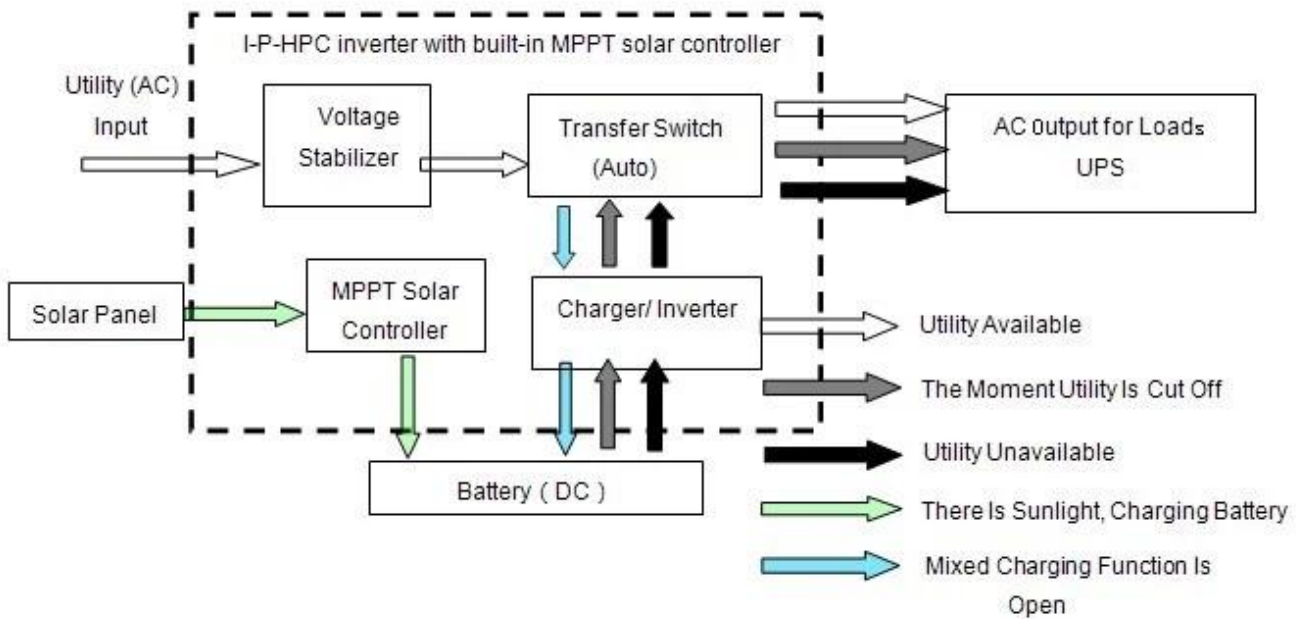

2.2 DC first, AC standby UPS mode:

When both utility and battery are connected to the inverter, battery will supply power to the loads prior to utility. When battery capacity is not enough, utility will continue to supply power automatically.

Steps are as follows:

Step 1: When battery has enough power, it will supply power to the loads directly

Step 2: When battery does not have enough power, it will automatically transfer to utility supplying power to the loads

Step 3: After the battery is fully charged (e.g. by solar or wind charge controller), it will then automatically transfer to battery supplying power to the loads.

See Workflow as below.

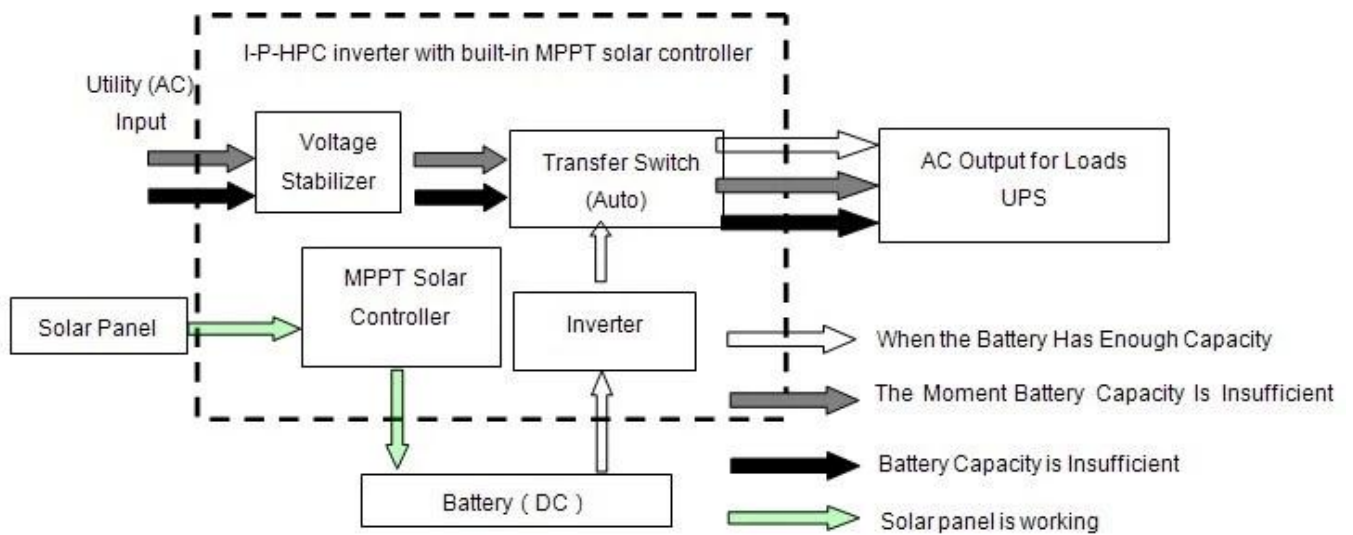

3. Timing function

There are 2 kinds of timing mode:



3.1 Timed on/off normal working mode and sleep mode: can set specific time when to open normal output and when to close AC output to enter sleep mode.

3.2 Battery and utility switchable mode: can set specific time when to use battery or utility supply power (suitable for areas where electric fee is charged according to period in different intervals)

4. Recording/checking function



4.1 Machine fault checking: can check the machine fault information

4.2 Discharge time checking: can check the discharge time of the battery

Parameter

Parameter		Model	1000W	1500W	2000W	3000W	4000W	5000W
Rated Output Power			1000W	1500W	2000W	3000W	4000W	5000W
Peak Power			2000W	3000W	4000W	6000W	8000W	10000W
Battery (Lead-acid battery)			24V	24V/48V(optional)			48V	
Charging Parameter								
Charge Mode[setting]			PV charge PV charge + utility charge					
MPPT Solar Controller	Voltage		24V	24V/48V			48V	
	Current		20A	25A	30A	40A	40A	40A
	Max PV Input Voltage		100V					
	PV Charge Efficiency		95%~99%					
	Max PV Input Power		568W	24V: 710W 48V:1420W	24V: 852W	24V:1136W 48V: 2272W	2272W	2272W
Utility	AC Charge Current		0~15A					
	Charge Mode		3-Stage Charging					
Inversion parameter								
AC Output	Voltage		220V±3% or 230V±3 or 240V±3% or 100V±3% or 110V±3% [optional]					
	Frequency		50Hz±0.5 or 60Hz±0.5 [optional]					
Output wave type			Pure sine wave output, waveform distortion rates≤3					
Overload ability			120% 1 min, 130% 10s					
Power Consumption (under normal working mode)			0.4A	24V: 0.5A 48V: 0.4A	24V: 0.7A	24V: 0.7A 48V: 0.5A	0.6A	0.65A
Power Consumption (under sleep mode)			1-6W					
Inverter Conversion Efficiency			85%~92%					
Utility Mode								
AC Input	Voltage		220V±35% or 110V+35%[optional]					
	Frequency		The same as utility					
AC Output	Voltage		220V±5% or 110V+5%[optional]					
	Frequency		The same as utility					
Overload Ability			120% 1 min, 130% 10s					
(AC first or DC first) priority								
UPS Output[setting]			AC first, DC standby DC first, AC standby					
Switch Time			5ms [AC to DC / DC to AC]					
Power On [setting]			Set by users Timed open / close AC output automatically					
General Parameter								
Display	Display Mode		LCD+LED					
	Display Information		Input voltage, output voltage, output frequency, battery capacity, Load condition, Status Information					
Protection			Overload output, short-circuit, high-voltage input, low-voltage input, overheat					
Environment	Temperature		-10°C~50°C					
	humidity		10%~90%					
	Altitude		≤4000m					
Size WxDxH(mm)			438*208*413			450*246*468		
Packing Size WxDxH(mm)			520*310*460			540*300*518		
Net Weight (kg)			15	17	19	25	34	35
Gross Weight (kg)			16	18	20	27	40	41

- The “optional” parameter can be set as per customer’s requirement
- The above is our standard parameter. Subject to change without prior notice.
- We have our own professional inverter and controller R&D team and we provide technical support and OEM service.

Connection Diagram

I-P-HPC-Series System



Others

Please refer to the outline design, technical documents, product brochures, etc.

Made by Engineering Department, May 15, 2014, 2nd Edition.