

I-P-SPC Series Low Frequency Solar Power [Inverter](#) with Built-in Solar Charge [Controller](#) 1500W



Component

- 1) High quality low frequency pure sine wave inverter (with utility charge function and [UPS function](#))
- 2) Built-in PWM solar power charge controller

Application

- 1) [Off-grid solar power system](#)
- 2) Utility and solar complementary power generation system

Features

- 1) Easy to install. To configure a solar system, users just need to connect it with solar panels and batteries.
- 2) CPU management, intelligent control, modular design
- 3) LED LCD display. LCD can display various parameters (such as the output voltage, frequency, working mode)
- 4) Multifunction design, [AVR UPS function](#). Users don't need to buy solar, controller, AC charger or stabilizer.
- 5) External battery connection, it's convenient for users to expand use time and back-up power time
- 6) With super load-carrying ability and high load capacity, this series of inverters can not only drive resistance load; but also various kinds of inductive loads such as motor, air conditioner, electric drills, fluorescent lamp, gas lamp. It can drive almost any kinds of load
- 7) Low frequency pure sine wave circuit design, stable quality, easy to maintenance, low failure rate and long service life (under proper operation, it can last at least 5 years)
- 8) Perfect protection: low voltage protection, high voltage protection, over temperature protection, short-circuit protection, overload protection
- 9) CE / EMC / LVD / RoHS / FCC approvals

10)2 years warranty, life-long technicalsupport

Function

Off-grid solarpower system

1. When connected withbattery and AC loads,users can set it to normal working mode or sleep mode.

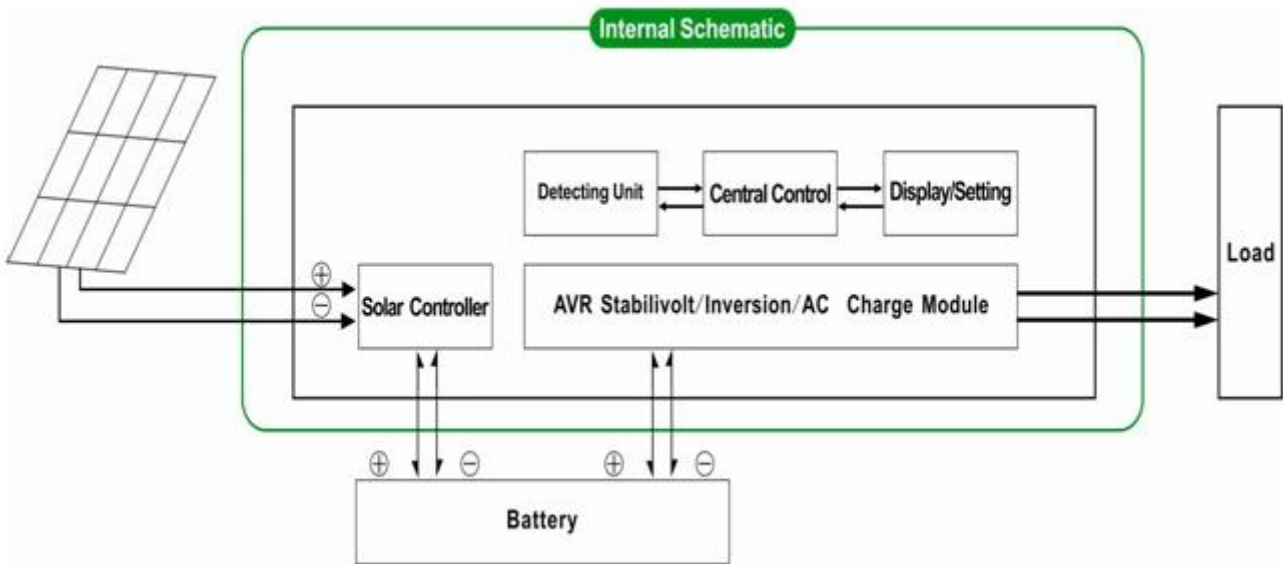

1.1 Normal workingmode□FREQUENCY in the LCD display is set to 01. No matterit’s connected AC loads or not, the inverter always convert DC to AC. It’s ready to supply power to the AC loads. Inthis mode, the LCD will display output voltage as bellow:

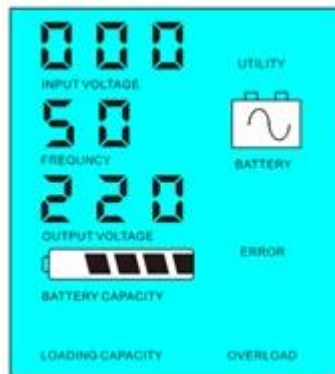

1.2 Sleep mode□FREQUENCY in the LCD display is set as 02.Ifthe power of the connected AC loads is lower than 5% of the inverter’s ratedpower, there will be no output from the inverter. Only the chip of inverter isworking. The power consumption of the inverter is only 1-6W. The LCD shows theoutput voltage 0. If the power of the connected loads is over 5%,then theinverter will automatically convert DC to AC to supply power for the loadswithin 5s. The LCD shows the output voltage. As shown below:

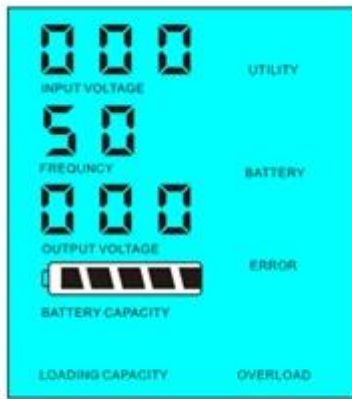

Load's power < 5% of inverter's rated power



Load's power > 5% of inverter's rated power

Kindly note:

- 1) Only the solar panel charges the battery
- 2) Off-grid solar power system. It is suitable for areas that are lack of utility or plentiful solar

Utility and solar complementary power generation system

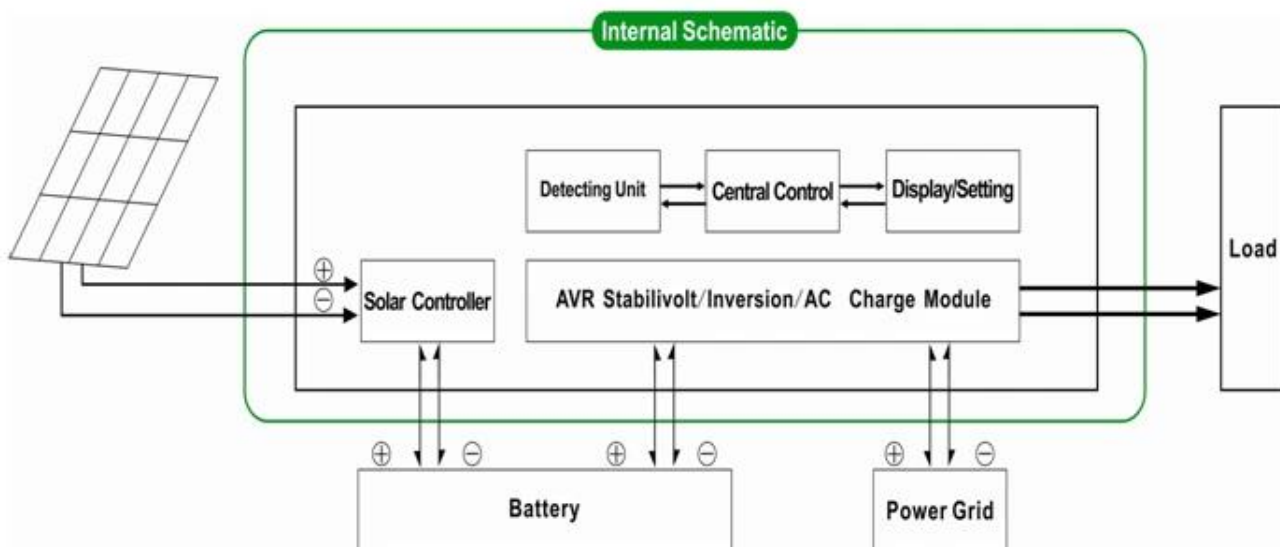

2. UPS function When the inverter is connected to battery and utility, users can set it to utility first (AC first) battery standby mode or battery first (DC first) utility standby mode.

2.1. Utility first (AC first) battery standby mode : FREQUENCY in the LCD display is set to 01. When utility and battery are connected to the inverter, utility will supply power to the loads prior. When utility is cut off, the battery will automatically continue to supply power via power inverter.

Steps are as follows:

Step 1: When utility is available, it will drive the loads directly after voltage being stabilized and at the same time charge batteries via power inverter .

Step 2: When utility is cut off, the inverter will convert DC to AC automatically to ensure uninterrupted power supply within 5ms.

Step 3: When utility is available again, inverter will automatically transfer to utility supplying power to loads and charge batteries via power inverter at the same time.

See Workflows below.

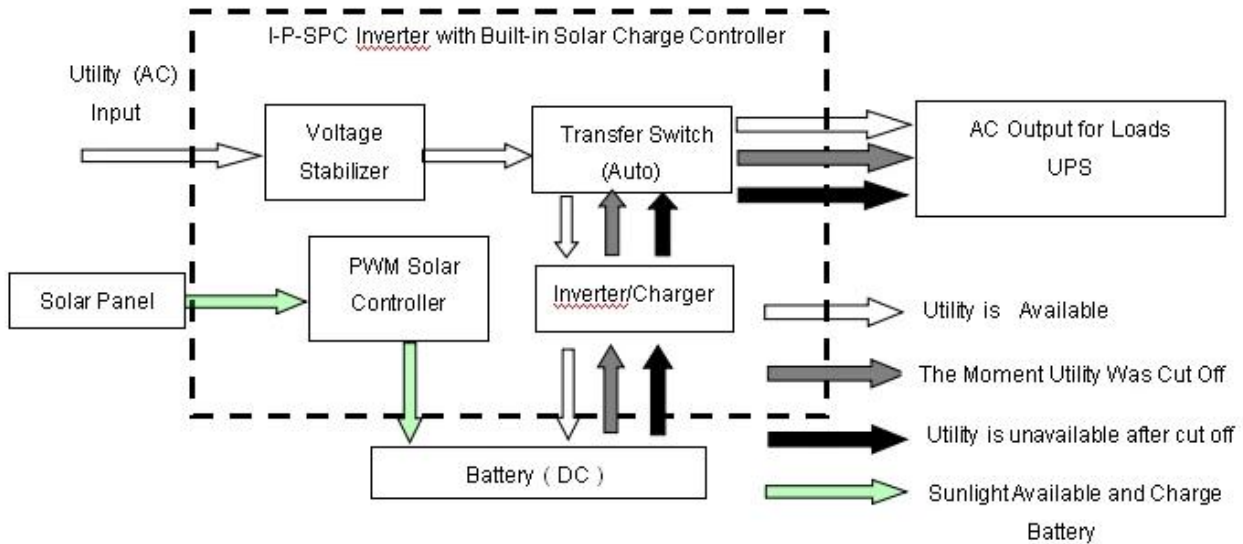

LCD displayed as bellow:

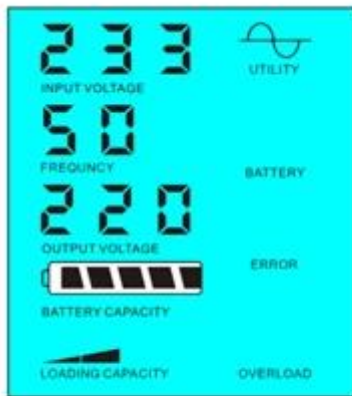

Utility supply power and charge battery

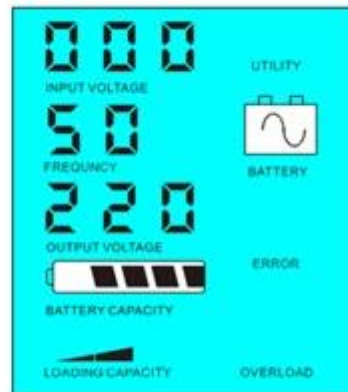

Without utility and battery supply power

Kindly note:

- 1) There are 2 ways to charge the battery, utility and solar panel
- 2) This system is suitable for power systems built in areas that lack utility. Or people can use solar and utility at the same time.

2.2. Battery first (DC first) utility standby mode: FREQUENCY in the LCD display is set as 03. When utility and battery are connected to the inverter, battery will supply power to the loads prior to utility. When

battery capacity is not enough, utility will continue to supply power automatically.

Steps are as follows:

Step 1: When battery is available, it will drive the AC loads via power inverter.

Step 2: When battery does not have enough power, it will automatically transfer to utility supplying power to the loads

Step 3: After the battery is fully charged (e.g. by solar or wind charge controller), it will automatically transfer to battery supplying power to the loads via power inverter.

See Workflow as below.

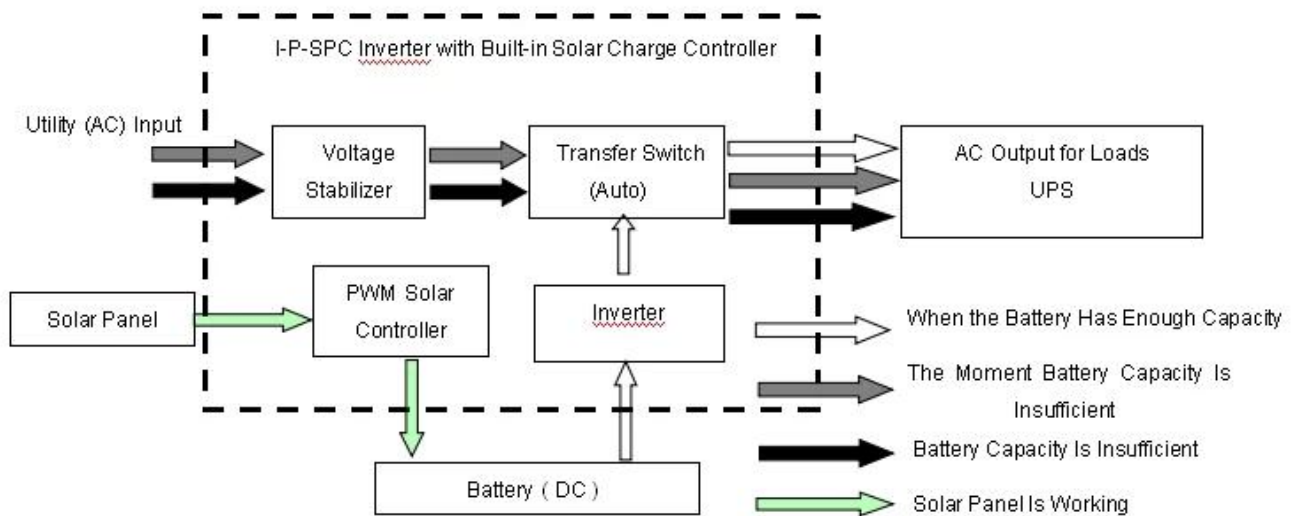

LCD displayed as below:

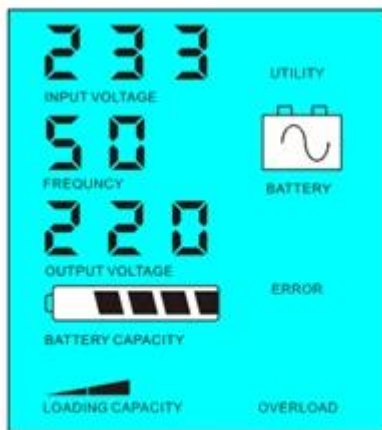

Battery available to supply power



Battery unavailable, utility supply power

Kindly note:

1) There is only one way to charge the battery: solar panel

2) This system is suitable for areas where electricity is expensive or environmental areas where solar power can be fully used to save utility bill. such as home solar & wind system, street light solar & wind

system

Parameter

Mode		2000VA
Rated Output Capacity		1500W
Peak Power		3000W
Battery Voltage(DC)		24V or 48V
PWM Solar Controller	Voltage	24V or 48V
	Current	30A
	PV Max Input Voltage	24V System□50V 48V System□100V
Size W×D×H(mm)		350*220*460
Packing Size W×D×H(mm)		370*240*480
Net Weight (kg)		20
Gross Weight (kg)		22
General Parameter		
Working Mode (Setting)	1	Utility first (AC first) battery standby mode
	2	Sleep Mode,no utility,load's power is over 5% of rated output power, Inverter start to work automatically
	3	Battery first (DC first)utility standby mode
AC Input	Voltage	220V±35% or 110V+35%□Optional□
	Frequency	50Hz±3% or 60Hz±3% □Optional□
AC Output	Voltage	220V±3% or 230V±3 or240V±3% or 100V±3% or 110V±3% (Optional)
	Frequency	50Hz±0.5 or 60Hz±0.5 (Optional)
Utility charge	AC Charge Current	0~15A
	Charge Time	Depend on battery capacity and quantity
	Battery Protection	Automatic detection, Charge and discharge protection□Intelligent Management
PV Charge		Total Current of PV Input Should Be Less Than Rated Current of PWM solar controller
Display	Display Mode	LCD+LED
	Display Information	Input voltage□output voltage□output frequency□battery capacity□Load condition□Status Information
Output Wave Type		Pure sine wave output,Total Harmonic Distortion THD≤3
Overload Ability		□120% 1 min□□130% 10s
Power Consumption	Sleep Mode	1~6W
	Normal Mode	1~3A
Conversion Efficiency		80%~90%
Transfer Time		□5ms □AC to DC / DC to AC□
Protection		Overload output□short-circuit□high-voltage input□low-voltage input□overheat
Environment	Temperature	-10°C□50°C
	Humidity	10%□90%
	Altitude	≤4000m

Theabove is our standard parameter. Subject to change without prior notice.

We have our own professional inverter and controller R&D team and we provide technical support and OEM ODM service.

The controller information above is our company's standard parameter. It can be changed to other PWM solar charge controller.

Connection Diagram



Others

Please see the outline of the design, technical documents, user manuals, product brochures, etc. Research and development department made 1st edition on May 5, 2014..