

IP-TPI2-1000W-6000W  
 AC  
 1 DC  
 50Hz  
 60Hz  
 TPI  
 24  
 UPS  
 DC  
 TV

&#038; NBSP  
 AC  
 insustrial  
 UPS

□□

**1.DC / AC**

· NBSP ON  
 S-ON

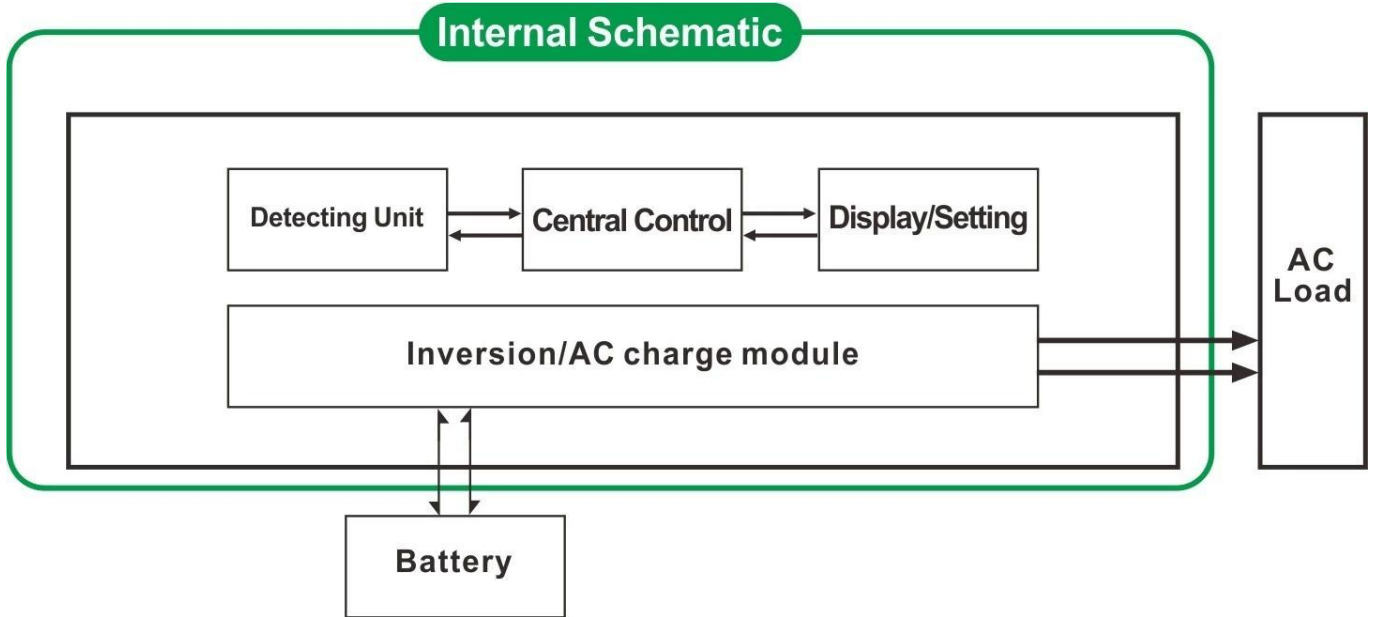

ON 1.1  
 LCD  
 1.2 S-ON  
 0  
 1-6W AC  
 5  
 LCD  
 CF

**2**

1  
 2 &#038; NBSP  
 3 3  
 CC  
 CV  
 CF



AC Input

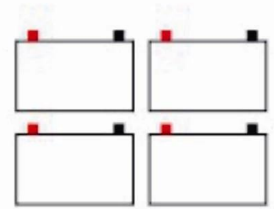
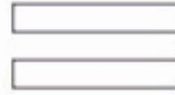
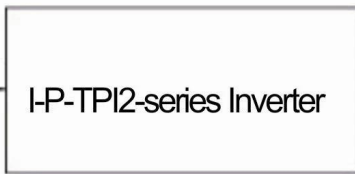

0 "0" 0

### 3 UPS

AC DC

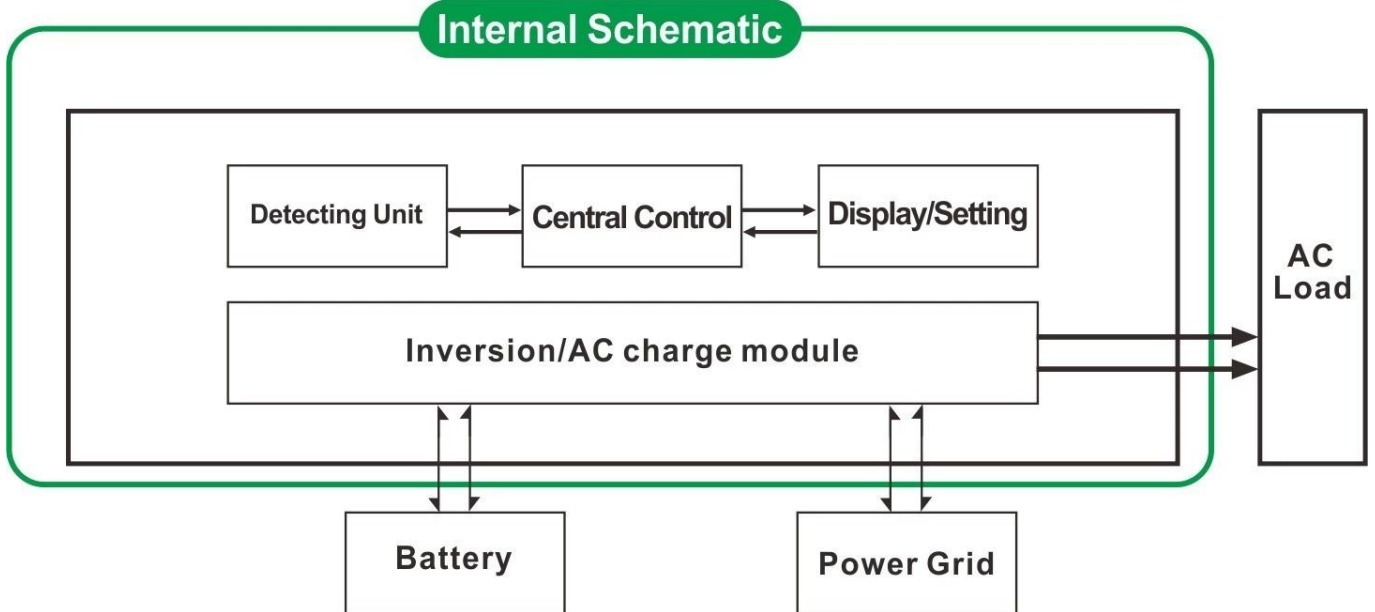

- 3.1 UPS AC
- 3.2 UPS DC

- 1
- 2 CPU
- 3 LCD LED
- 4 AC DC 50Hz 60Hz
- 5 87 98 1W 6W
- 6 8
- 7
- 8 3 1KW 1HP 2KW 2HP 3KW 3HP
- 9 5
- 10
- 11 EMC LVD RoHS
- 12 2

6000W
6000W

额定功率		18000W	
输入/输出DC		24V/48V	
外形尺寸(W×D×H)mm		440 * 218 * 400	
安装尺寸(W×D×H)mm		520 * 275 * 520	
重量(kg)		51	
净重(kg)		53	
控制方式	控制	本地/远程	
	S-ON	1.6W 5.0W	
	控制	控制	
AC输入	电压	220V±3% 35 110V + 35±	
	频率	50Hz/60Hz	
AC输出	电压	220V±3% ±230V 3 240V±3% 100V±3% 110V±3%	
	频率	DC / AC 50Hz/60Hz	
输入/输出	AC输入	24V	48V
	MAX	75A	50A
	控制	1.2W 2.0W OEM	
	控制	CC/CV/CF	
	控制	控制	
UPS	AC	控制	
	DC	控制	
控制	控制	+LED	
	控制	控制	
控制		控制	
控制		> 120 1 > 130 10	
控制	控制	1.6W	
	控制	1.3A	
控制		87 98	
控制		< 5ms AC / DC AC	
控制		控制	
控制	控制	-10°C 50°C	
	控制	10 90	
	控制	≤4000m	

00



# Certificate Of Registration

## QUALITY MANAGEMENT SYSTEM

This is to Certify that the Quality Management System  
of  
**SHENZHEN I-PANDA NEW ENERGY TECHNOLOGY  
& SCIENCE CO., LTD.**

**Address:**

*Block H, Juyin Technology Industrial Park, Buji St., Longgang Dist., Shenzhen,  
518000, Guangdong, China.*

*has been assessed and found to comply with the requirements of:*

# ISO 9001:2008

**(Quality Management System)**

Clause 7 permissible Exclusions: Nil

Scope of Certification:

**Design, Production and Sales of Power Inverter, Solar Controller, Solar  
Generator System and UPS.**

Sector Code: (ANZSIC CODE: 2859)

Certificate Number: CHIN/TW/QMS/00119

Issue no.: 01

Date of approval : 05.07.2014

Valid until : 04.07.2017

Revision no: nil

Revision date : nil

Original Certification Date: 05.07.2014



Surveillance Audit 1st Year

  
Managing Director



Surveillance Audit 2nd year

**MS CERTIFICATION SERVICES PVT. LTD.**

[www.ms certification.net](http://www.ms certification.net)

The Certificate is Valid Only if the Annual Surveillance Mark is Signed by Auditor on Original.

PK00001



# Certificate Of Registration

## ENVIRONMENTAL MANAGEMENT SYSTEM

This is to certify that the Environmental Management System  
of

**SHENZHEN I-PANDA NEW ENERGY TECHNOLOGY  
& SCIENCE CO., LTD.**

**Address:**

**Block H, Juyin Technology Industrial Park, Buji St., Longgang Dist., Shenzhen,  
518000, Guangdong, China.**

*has been assessed and found to comply with the requirements of:*

# ISO 14001:2004

**(Environmental Management System)**

*Scope of Certification:*

**Design, Production and Sales of Power Inverter, Solar Controller,  
Solar Generator System and UPS.**

**Sector Code: (ANZSIC CODE: 2859)**

**Certificate Number: CHIN/TW/EMS/00028**

*Issue no.: 01*

*Date of approval : 05.07.2014  
Revision no: nil*

*Valid until : 04.07.2017  
Revision date : nil*

*Original Certification Date: 05.07.2014*



Surveillance Audit 1st Year

**Managing Director**



Surveillance Audit 2nd year

**MS CERTIFICATION SERVICES PVT. LTD.**

[www.ms certification.net](http://www.ms certification.net)

*The Certificate is Valid Only if the Annual Surveillance Mark is Signed by Auditor on Original.*

PG/EMS/01.02



Best Service of Testing  
since 2003

# Certificate of Compliance

**Certificate NO. :** BST14050326Y-1EC-1

**Applicant :** SHENZHEN I-PANDA NEW ENERGY TECHNOLOGY & SCIENCE CO., LTD.  
Bolck H, Juyin Technology Industrial Park, Buji St.,  
Longgang Dist., Shenzhen, Guangdong, China

**Manufacturer :** SHENZHEN I-PANDA NEW ENERGY TECHNOLOGY & SCIENCE CO., LTD.  
Bolck H, Juyin Technology Industrial Park, Buji St.,  
Longgang Dist., Shenzhen, Guangdong, China

**Product Name :** PURE SINE WAVE INVERTER WITH CHARGER AND UPS

**Trade Name :** I-PANDA

**Main Test Model :** I-P-TPI-6000W

**Additional Model :** I-P-TPI-1000W, I-P-TPI-2000W, I-P-TPI-3000W,  
I-P-TPI-4000W, I-P-TPI-5000W

**Test Standard :** EN 55022:2010  
EN 61000-3-2:2006+A1:2009+A2:2009  
EN 61000-3-3:2013  
EN 55024:2010

**As shown in the Test Report No. :** BST14050326Y-1ER-1.

The EUT described above has been tested by us with the listed standards and found in compliance with the council EMC directive 2004/108/EC. It is possible to use CE marking to demonstrate the compliance with this EMC Directive.

The certificate applies to the tested sample above mentioned only and shall not imply an assessment of the whole production.



Christina  
Manager  
May 20, 2014

**Shenzhen BST Technology Co.,Ltd.**

Add: Building No.23-24, Zhiheng Industrial Park, Guankouer Road, Nantou, Nanshan District, Shenzhen, Guangdong, China

Certificate Search: <http://www.bst-lab.com>, Tel:400-882-9628, 8009990305, E-mail:christina@bst-lab.com



Best Service of Testing  
since 2003

# Certificate of Compliance

**Certificate NO. :** BST14050326Y-1SC-2

**Applicant :** SHENZHEN I-PANDA NEW ENERGY TECHNOLOGY & SCIENCE CO., LTD.  
Bolck H, Juyin Technology Industrial Park, Buji St., Longgang Dist., Shenzhen, Guangdong, China

**Manufacturer :** SHENZHEN I-PANDA NEW ENERGY TECHNOLOGY & SCIENCE CO., LTD.  
Bolck H, Juyin Technology Industrial Park, Buji St., Longgang Dist., Shenzhen, Guangdong, China

**Product Name :** PURE SINE WAVE INVERTER WITH CHARGER AND UPS

**Trade Name :** I-PANDA

**Main Test Model :** I-P-TPI-6000W

**Additional Model :** I-P-TPI-1000W, I-P-TPI-2000W, I-P-TPI-3000W, I-P-TPI-4000W, I-P-TPI-5000W

**Test Standard :** EN 60950-1:2006+A11:2009+A1:2010+A12:2011

**As shown in the Test Report No. :** BST14050326Y-1SR-2

The EUT described above has been tested by us with the listed standards and found in compliance with the council LVD directive 2006/95/EC. It is possible to use CE marking to demonstrate the compliance with this LVD Directive.

The certificate applies to the tested sample above mentioned only and shall not imply an assessment of the whole production.



Christina  
Manager  
May , 25, 2014

**Shenzhen BST Technology Co., Ltd.**

Add: Building No.23-24, Zhiheng Industrial Park, Guankouer Road, Nantou, Nanshan District, Shenzhen, Guangdong, China

Certificate Search: <http://www.bst-lab.com>, Tel: 400-882-9628, 8009990305, E-mail: christina@bst-lab.com



Best Service of Testing  
since 2003

## FCC VERIFICATION OF CONFORMITY

BST14050326Y-1EC-3

We herewith confirm the following designated product:

**Product Name: PURE SINE WAVE INVERTER WITH CHARGER AND UPS**

**Trade Name: I-PANDA**

**Main Test Model. : I-P-TPI-6000W**

**Additional Model: I-P-TPI-1000W, I-P-TPI-2000W, I-P-TPI-3000W,  
I-P-TPI-4000W, I-P-TPI-5000W**

(Product Identification)

has been tested and found in compliance with the requirements of 47 CFR PART 15 regulation & ANSI C63.4 for the evaluation of Class B of electromagnetic compatibility. It is only valid in connection with the test report number: BST14050326Y-1ER-3.

This device complies with Part 15 of the FCC rules, operation is subject to the following two conditions:

- (1) this device may not cause harmful interference, and
- (2) this device must accept any interference received, including interference that may cause undesired operation.

(Identification of regulations/standards)

This declaration is the responsibility of the manufacturer/importer

**SHENZHEN I-PANDA NEW ENERGY TECHNOLOGY & SCIENCE CO., LTD.**

**Bolck H, Juyin Technology Industrial Park, Buji St.,  
Longgang Dist., Shenzhen, Guangdong, China**

(Name /Address)

**MANUFACTURER / IMPORTER**



### TEST LABORATORY

This is the results of test that was carried out by Shenzhen BST, from the submitted type samples of the product is in conformity with the specification of the respective standards.

The certificate holder has the right to fix the FCC-mark on the product complying with the required rules.



Christina

Manager

May 20, 2014

Shenzhen BST Technology Co.,Ltd.

Add: Building No.23-24, Zhiheng Industrial Park, Guankouer Road, Nantou, Nanshan District, Shenzhen, Guangdong, China.

Certificate Search: <http://www.bst-lab.com>, Tel:400-882-9628, 8009990305, E-mail:christina@bst-lab.com





Best Service of Testing  
since 2003

# Certificate of Compliance

**Certificate NO. :** BST14050326Y-1RC-4

**Applicant :** SHENZHEN I-PANDA NEW ENERGY TECHNOLOGY & SCIENCE CO., LTD.  
Bolck H, Juyin Technology Industrial Park, Buji St., Longgang Dist., Shenzhen, Guangdong, China

**Manufacturer :** SHENZHEN I-PANDA NEW ENERGY TECHNOLOGY & SCIENCE CO., LTD.  
Bolck H, Juyin Technology Industrial Park, Buji St., Longgang Dist., Shenzhen, Guangdong, China

**Product Name :** PURE SINE WAVE INVERTER WITH CHARGER AND UPS

**Trade Name :** I-PANDA

**Main Test Model :** I-P-TPI-6000W

**Additional Model :** I-P-TPI-1000W, I-P-TPI-2000W, I-P-TPI-3000W, I-P-TPI-4000W, I-P-TPI-5000W

**Test Standard :** EPA3050B:1996、EN1122B:2001、EPA3052:1996、EPA3060A:1996、EPA7196A:1992、EPA3540C:1996、EPA8270D:2007、IEC62321:2008

**As shown in the Test Report No. :** BST14050326Y-1RR-4.

The EUT described above has been consolidated by us and found in compliance with the council RoHS directive—2011/65/EU.



## RoHS



Christina  
Manager  
May 20, 2014

**Shenzhen BST Technology Co.,Ltd.**

Add: Building No.23-24, Zhiheng Industrial Park, Guankouer Road, Nantou, Nanshan District, Shenzhen, Guangdong, China

Certificate Search: <http://www.bst-lab.com>, Tel:400-882-9628, 8009990305, E-mail:christina@bst-lab.com

**Service**

1 OEM ODM

