



1.1 在ON状态下，AC输入

当AC输入正常时，LCD显示0，表示AC输入正常。

1.2 在S-ON状态下，LCD显示5，表示AC输入正常。当AC输入正常时，LCD显示0，表示AC输入正常。当AC输入正常时，LCD显示0，表示AC输入正常。

2. 在待机状态下

当AC输入正常时，LCD显示8，表示AC输入正常。

当AC输入正常时，LCD显示8，表示AC输入正常。

当AC输入正常时，LCD显示8，表示AC输入正常。



当AC输入正常时，LCD显示0，表示AC输入正常。

3. UPS内部

当AC输入正常时，LCD显示DC，表示AC输入正常。

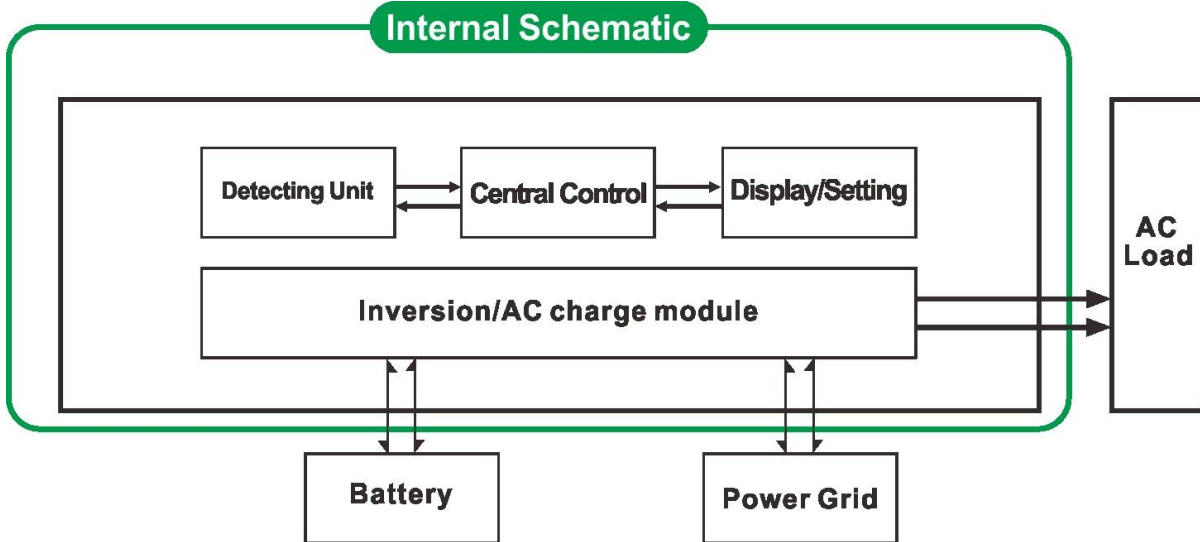

3.1 在UPS内部，AC输入

当AC输入正常时，LCD显示DC，表示AC输入正常。

当AC输入正常时，LCD显示DC，表示AC输入正常。

当AC输入正常时，LCD显示DC，表示AC输入正常。

当AC输入正常时，LCD显示DC，表示AC输入正常。

当AC输入正常时，LCD显示DC，表示AC输入正常。

当AC输入正常时，LCD显示DC，表示AC输入正常。

当AC输入正常时，LCD显示DC，表示AC输入正常。

当AC输入正常时，LCD显示DC，表示AC输入正常。

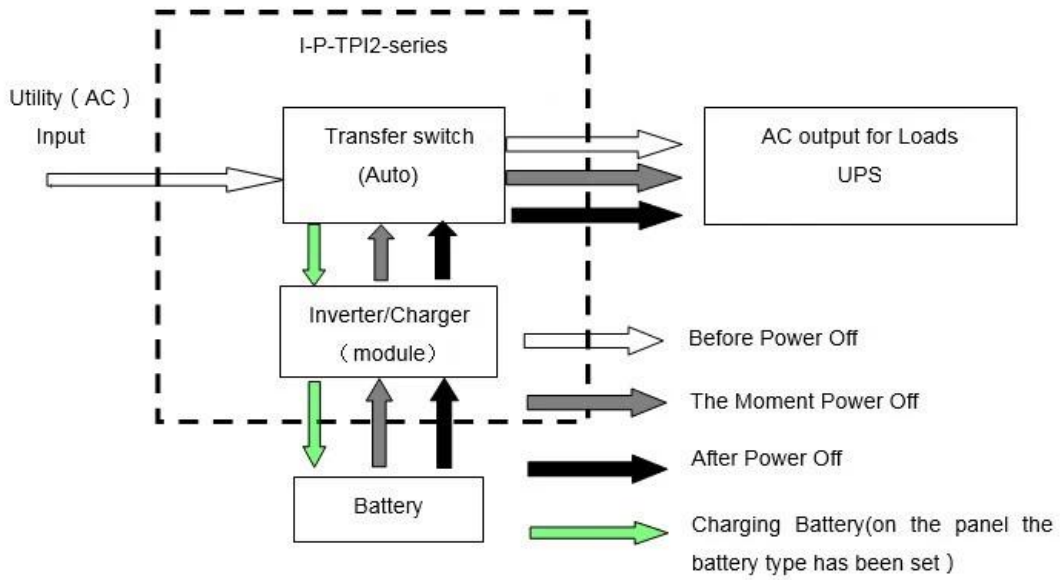

### 3.2 UPS DC

0

1

2

3



□□□□		87□□□□□□98□□□□□□
□□□□		□□□□□□□□□□□□□□□□
□□		□□□□□□□□□□
	□□	-10°C□50°C
□□	□□	□90□□10□
	□□	≤4000m



BAT Type



S-ON



AC

50HZ

AC



60HZ

DC



Inverter



Charger

Next Page



Alarm



OFF

ON



S-ON

# Power Inverter



DC-



DC INPUT		
12V	24V	48V
	✓	

DC+



Remote Port



AC OUTPUT



MAX 5A

AC INPUT | AC OUTPUT



L N E | L N E

Inverter  
Output Protect



Charger  
Input Protect





