

1.1 01 AC LCD

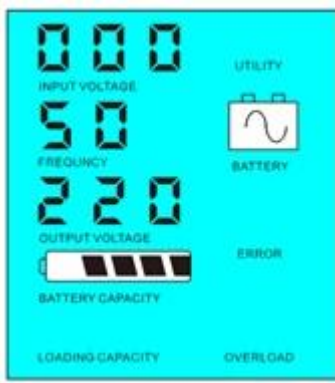

1.2 02. If 5 LCD

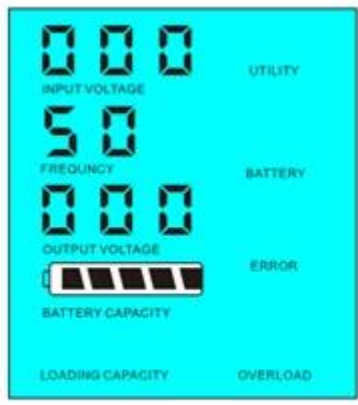

Load's power < 5% of inverter's rated power



Load's power > 5% of inverter's rated power

1

2

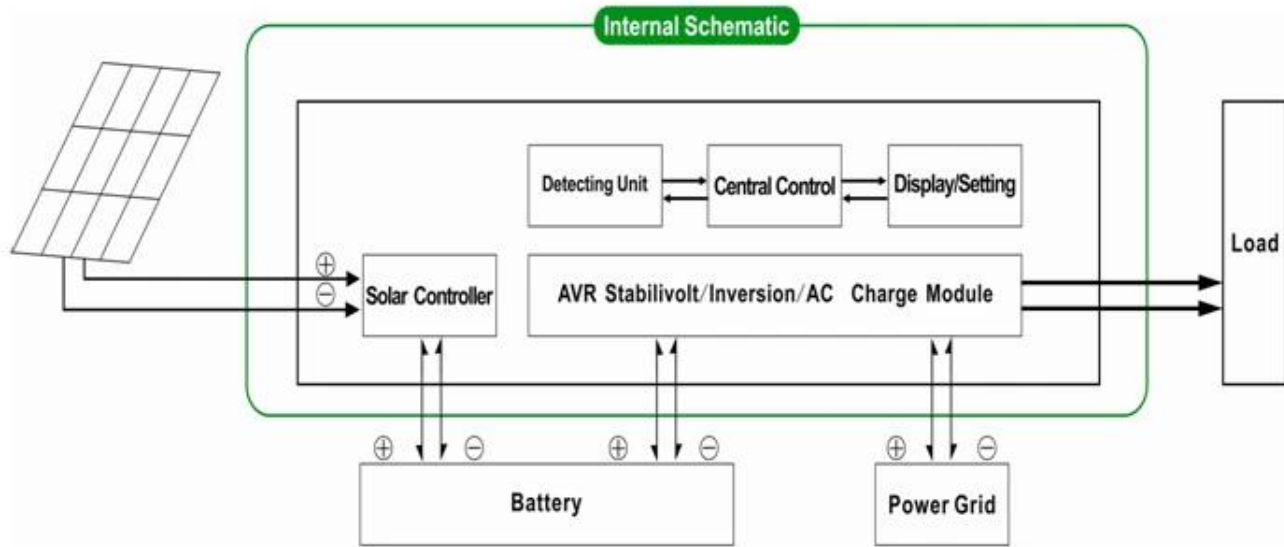

2 UPS AC 1 DC

2.1. Utility AC 01

1

2 5ms

3

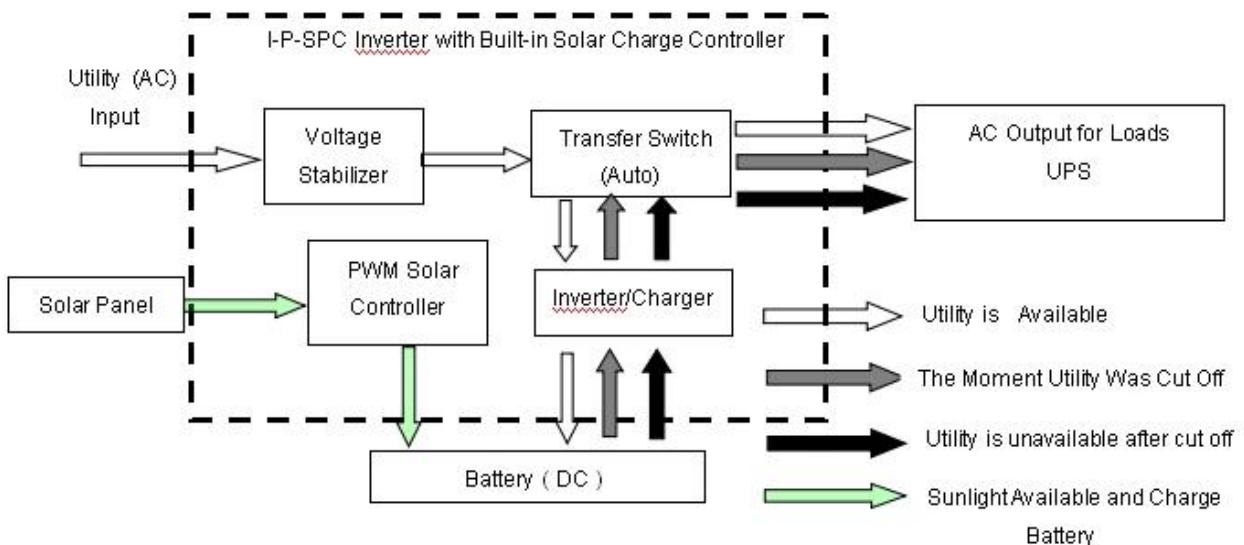

LCD

