

1.2 当频率FREQUNCY LCD显示02.If 当频率显示5时，输出为0，当频率显示1-6W时，输出为0，当频率显示5时，输出为5s，当输出为0时，输出为0。

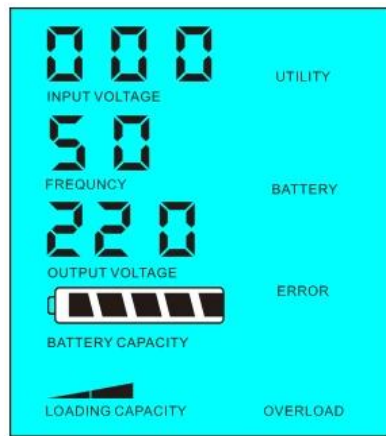
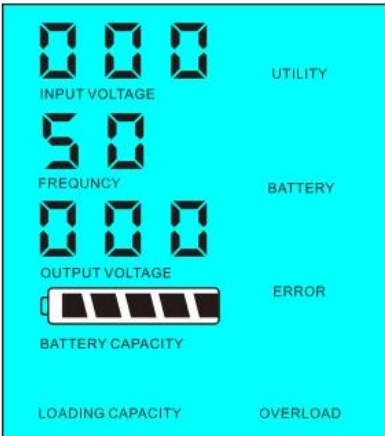

当频率 < 5 时

当频率 > 5 时

2 UPS 内部结构图 AC 输入 DC 输出

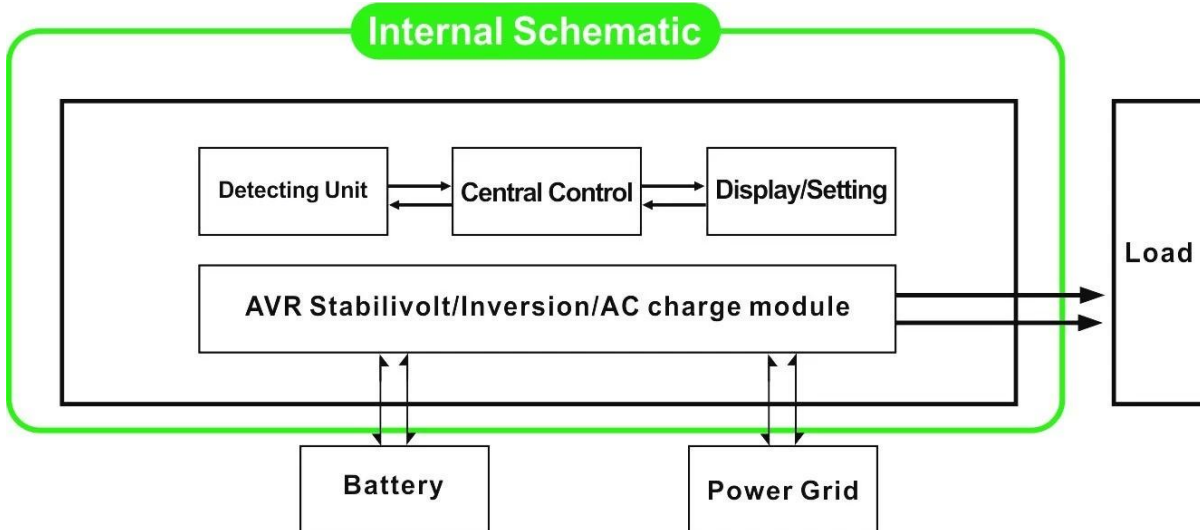

2.1 AC 输入电压检测精度为 0.1%，当输入电压波动时，输出为 0。

1.

1. 当输入电压波动时，输出为 0。

2. 当输入电压波动时，输出为 5ms。

3. 当输入电压波动时，输出为 0。

当输入电压波动时



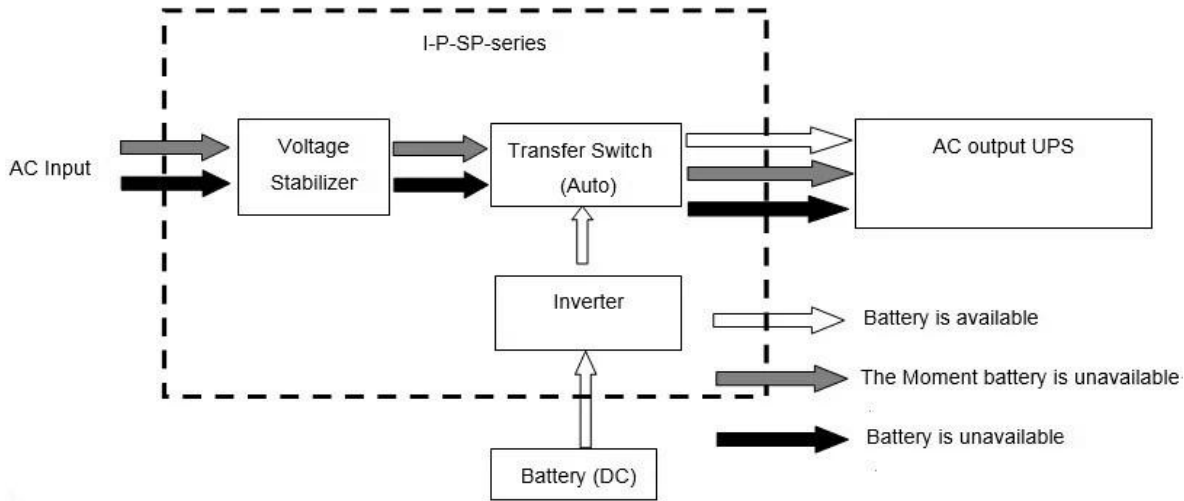

LCD

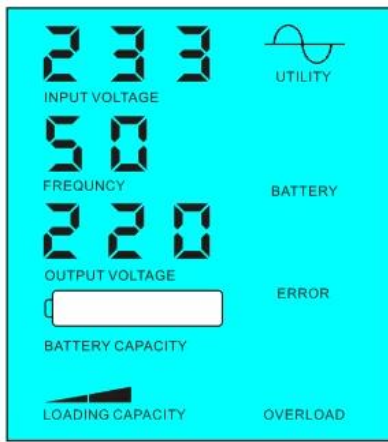
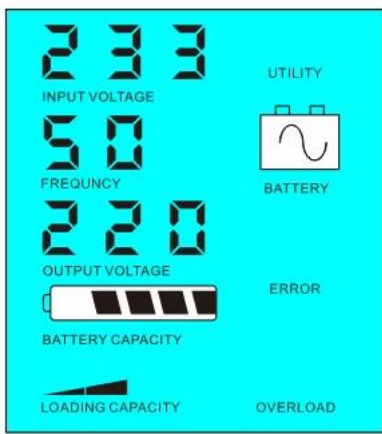

0000

0000000000

00

8000VA	
Power	6000W
Power	12000W
DC Voltage	96V / 192V
Dimensions (mm)	420 * 260 * 605
Dimensions (mm)	440 * 280 * 625
Weight	55
Weight	65
Outputs	
1	AC
2	AC
3	DC/UPS
AC	220V±35% 110V + 35%
AC	50Hz±3% 60Hz±3%
AC	220V±3% 230V±3% 240V±3% 100V±3% 110V±3%
AC	50Hz±0.5% 60Hz±0.5%
	AC 15A
	THD ≤ 3
	> 120 1 > 130 10S















中外运敦豪