



MPPT MPPT PV BCHARGE
RS232 / LAN



MASTER 80A-100A

12V/24V/36V/48V

Brandnew Series of I-Panda

MPPT Solar Charge Controller



1. MPPT MPPT ≥ 99.5
 - 2.
 3. PV PV+
 4. Battery
 5. gel FCUN
 6. PV
 - 7.
 - 8.
 9. RS485
 10. PC WiFi
 11. CE ROHS FCC
- 12 3 3 10



MPPT		48BL-80A	48bh-80a	
MPPT	MPPT	MPPT ≥ 99.5		
		0.5W 1.2W		
			48V	
Max.PV	Max.PV VOC	DC150V	DC300V	
		+ 3V	+ 10V	
		+ 2V	+ 5V	
		DC150V	DC300V	
	12V/24V/36V/48V	12V	1040W	
		24V	2080W	
		36V	3120W	
48V		4160W	4160W	

MPPT

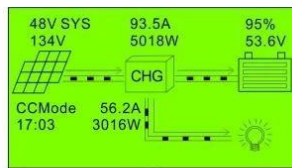
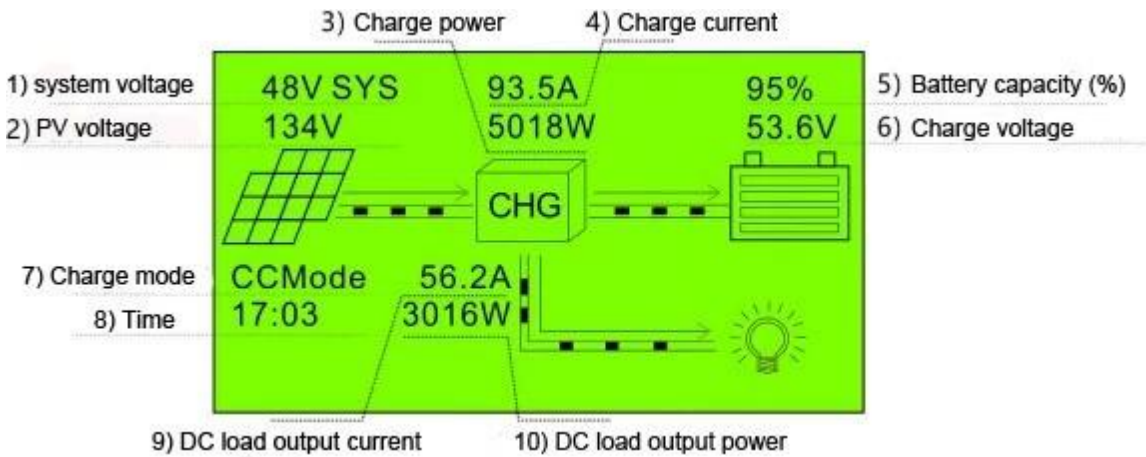

Main Menu
 1.Work Status
 2.Setting
 3.Information

Normal Mode
 Fault: NoFault
 CC Charging
 PV Volt: 134V

Normal Mode
 Chg Curr : 93.5A
 Chg Powr : 5018W
 Chg Volt : 53.6V

Normal Mode
 Chg Curr : 93.5A
 Chg Powr : 5018W
 Chg Volt : 53.6V

Normal Mode
 Bat Temp: 28C
 HS Temp: 48C
 Load Curr: 56.2A

Setting
 *1.Ethernet set
 2.Load Set
 3.Time&Data Set

Setting
 1.Ethernet set
 *2.Load Set
 3.Time&Data Set

Setting
 1.Ethernet set
 2.Load Set
 *3.Time&Data Set

Setting
 2.Load Set
 3.Time&Data Set
 *4.Bat Set

Information
 MPPT CHARGER
 12/24/36/48V 100A
 48V BAT CHG SYS

IP:192.168.1.18
 GT:192.168.1.1
 Port:8888
 ADR:1

Load: Time Ctrl
 Total: 0.0KWH
 Firmware: 1.0
 Bat: CustomDef

