

I-P-SPC Power Inverter with Built-in Solar Charge Controller 7000W



Application

- 1) [Off-grid solar power system](#)
- 2) [Utility and solar complementary power generation system](#)

Features

- 1) Easy to install. To configure a solar system, users just need to connect it with solar panels and batteries.
- 2) CPU management, Intelligent control, modular design
- 3) LED LCD display. LCD can display various parameters (such as the output voltage, frequency, working mode)
- 4) Multifunction design, AVR UPS function. Users don't need to buy solar, controller, AC charger or stabilizer.
- 5) External battery connection, it's convenient for users to expand use time and back-up power time
- 6) With super load-carrying ability and high load capacity, this series of inverters can not only drive resistance load; but also various kinds of inductive loads such as motor, air conditioner, electric drills, fluorescent lamp, gas lamp. It can drive almost any kinds of load
- 7) Low frequency pure sine wave circuit design, stable quality, easy to maintenance, low failure rate and long service life (under proper operation, it can last at least 5 years)

8) Perfect protection: low voltage protection, high voltage protection, overtemperature protection, short-circuit protection, overload protection

9) CE/ EMC / LVD/ RoHS /FCC approvals

10) 2years warranty, life-long technical support

Parameter

Mode	10KVA	
Rated Output Capacity	7000W	
Peak Power	14000W	
Battery Voltage(DC)	96V	
PWM Solar Controller	Voltage	96V
	Current	50A
	PV Max Input Voltage	200V
Size W×D×H(mm)	420*260*605	
Packing Size W×D×H(mm)	440*280*625	
Net Weight (kg)	55	
Gross Weight (kg)	65	
General Parameter		
Working Mode (Setting)	1	Utility first (AC first) battery standby mode
	2	Sleep Mode, no utility, load's power is over 5% of rated output power, Inverter start to work automatically
	3	Battery first (DC first) utility standby mode
AC Input	Voltage	220V±35% or 110V+35% □Optional□
	Frequency	50Hz±3% or 60Hz±3% □Optional□
AC Output	Voltage	220V±3% or 230V±3 or 240V±3% or 100V±3% or 110V±3% (Optional)
	Frequency	50Hz±0.5 or 60Hz±0.5 (Optional)
Utility charge	AC Charge Current	0~15A
	Charge Time	Depend on battery capacity and quantity
	Battery Protection	Automatic detection, Charge and discharge protection □Intelligent Management
PV Charge	Total Current of PV Input Should Be Less Than Rated Current of PWM solar controller	
Display	Display Mode	LCD+LED
	Display Information	Input voltage □output voltage □output frequency □battery capacity □Load condition □Status Information
Output Wave Type	Pure sine wave output, Total Harmonic Distortion THD≤3	
Overload Ability	□120% 1 min □□130% 10s	
Power Consumption	Sleep Mode	1~6W
	Normal Mode	1~3A
Conversion Efficiency	80%~90%	
Transfer Time	□5ms □AC to DC / DC to AC□	
Protection	Overload output □short-circuit □high-voltage input □low-voltage input □overheat	
Environment	Temperature	-10°C □50°C
	Humidity	10% □90%
	Altitude	≤4000m

Off-grid solar power system

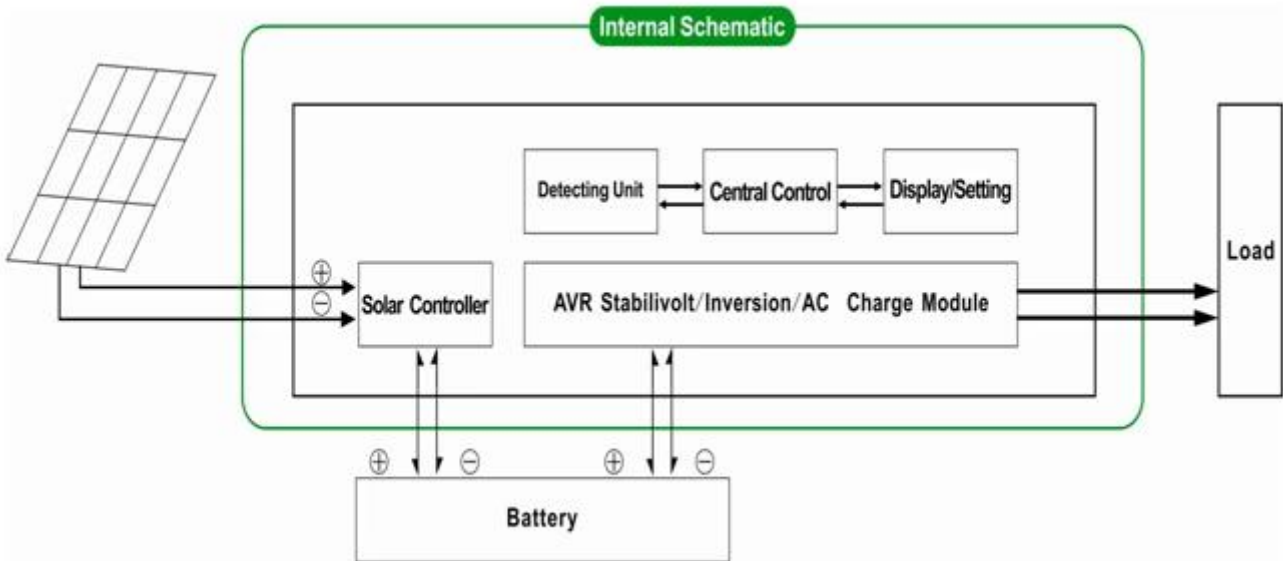

Utility and solar complementary power generation system

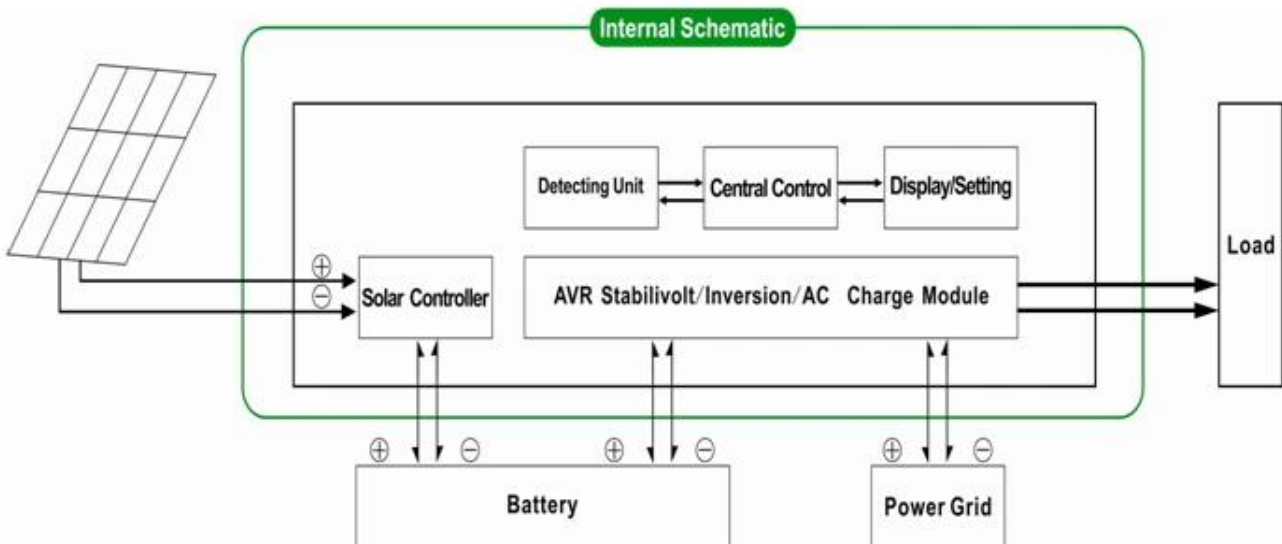

The above is our standard parameter. Subject to change without prior notice.

We have our own professional inverter and controller R&D team and we provide technical support and OEM ODM service

The [controller](#) information above is our company's standard parameter. It can be changed to other PWM solar charge controller.

Connection Diagram

I-P-SPC-Series System



I-P-SPC-Series Inverter+Solar Controller

