

I-P-SPC Power Inverter with Built-in Solar Charge Controller 20000W



Application

- 1) Off-grid solar power system
- 2) Utility and solar complementary power generation system

Features

- 1) Easy to install. To configure a solar system, users just need to connect it with solar panels and batteries.
- 2) CPU management, Intelligent control, modular design
- 3) LED LCD display. LCD can display various parameters (such as the output voltage, frequency, working mode)
- 4) Multifunction design, AVR UPS function. Users don't need to buy solar, controller, AC charger or stabilizer.
- 5) External battery connection, it's convenient for users to expand use time and back-up power time
- 6) With super load-carrying ability and high load capacity, this series of inverters can not only drive resistance load; but also various kinds of inductive loads such as motor, air conditioner, electric drills, fluorescent lamp, gas lamp. It can drive almost any kinds of load
- 7) Low frequency pure sine wave circuit design, stable quality, easy to maintenance, low failure rate and long service life (under proper operation, it can last at least 5 years)

8) Perfect protection: low voltage protection, high voltage protection, overtemperature protection, short-circuit protection, overload protection

9) CE/ EMC / LVD/ RoHS /FCC approvals

10) 2years warranty, life-long technical support

Parameter

Mode		30KVA
Rated Output Capacity		20KW
Peak Power		40KW
Battery Voltage(DC)		192V
PWM Solar Controller	Voltage	192V
	Current	50A
	PV Max Input Voltage	400V
Size W×D×H(mm)		420*280*625
Packing Size W×D×H(mm)		440*300*645
Net Weight (kg)		125
Gross Weight (kg)		135
General Parameter		
Working Mode (Setting)	1	Utility first (AC first) battery standby mode
	2	Sleep Mode,no utility,load's power is over 5% of rated output power, Inverter start to work automatically
	3	Battery first (DC first)utility standby mode
AC Input	Voltage	220V±35% or 110V+35% □Optional□
	Frequency	50Hz±3% or 60Hz±3% □Optional□
AC Output	Voltage	220V±3% or 230V±3 or240V±3% or 100V±3% or 110V±3% (Optional)
	Frequency	50Hz±0.5 or 60Hz±0.5 (Optional)
Utility charge	AC Charge Current	0~15A
	Charge Time	Depend on battery capacity and quantity
	Battery Protection	Automatic detection, Charge and discharge protection□Intelligent Management
PV Charge		Total Current of PV Input Should Be Less Than Rated Current of PWM solar controller
Display	Display Mode	LCD+LED
	Display Information	Input voltage□output voltage□output frequency□battery capacity□Load condition□Status Information
Output Wave Type		Pure sine wave output, Total Harmonic Distortion THD≤3
Overload Ability		□120% 1 min□□130% 10s
Power Consumption	Sleep Mode	1~6W
	Normal Mode	1~3A
Conversion Efficiency		80%~90%
Transfer Time		□5ms □AC to DC / DC to AC□
Protection		Overload output□short-circuit□high-voltage input□low-voltage input□overheat

Environment	Temperature	-10°C~50°C
	Humidity	10%~90%
	Altitude	≤4000m

Off-grid solar power system

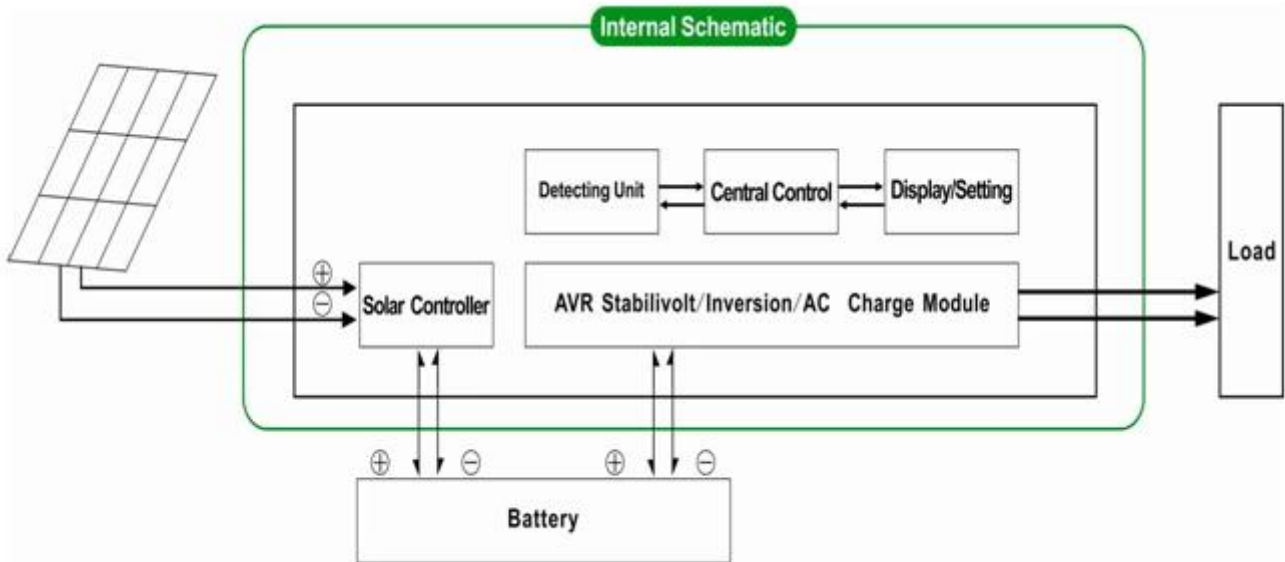

Utility and solar complementary power generation system

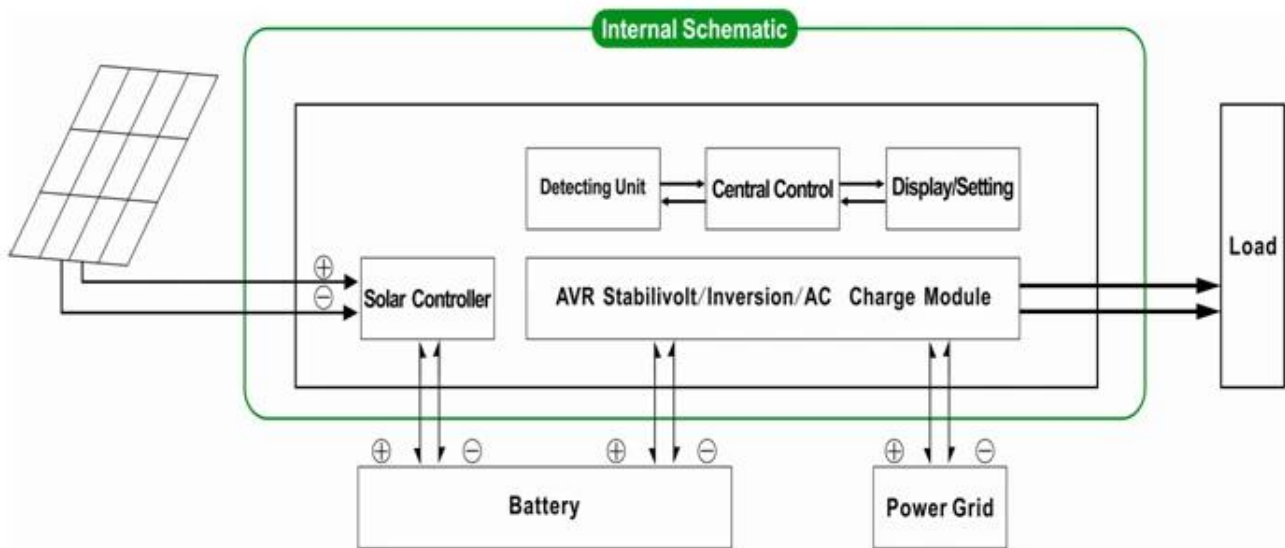

The above is our standard parameter. Subject to change without prior notice.

We have our own professional inverter and [controller](#) R&D team and we provide technical support and OEM ODM service

The [controller](#) information above is our company's standard parameter. It can be changed to other PWM [solar charge controller](#).

ConnectionDiagram

I-P-SPC-Series System



I-P-SPC-Series Inverter+Solar Controller



