

1.2 LCD display shows FREQUENCY 50. If the load power is less than 5% of the inverter's rated power, the LCD displays 000 for the output voltage. If the load power is more than 5% of the inverter's rated power, the LCD displays 220 for the output voltage.



Load's power < 5% of inverter's rated power



Load's power > 5% of inverter's rated power

1. LCD display shows

1. LCD display shows

2. LCD display shows

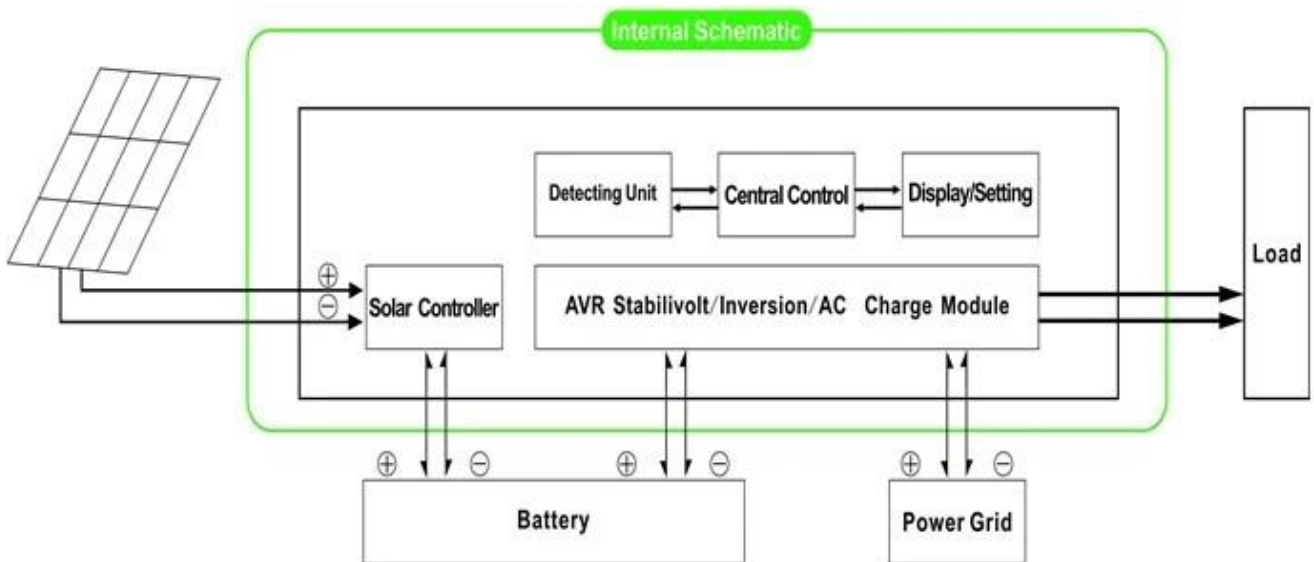

2. UPS 的 功 能 是 將 AC 電 源 轉 換 成 DC 電 源 供 負 載 使 用 。

2.1. Utility 的 AC 電 源 經 過 LCD 電 源 轉 換 成 DC 電 源 供 負 載 使 用 。

功 能 詳 見 下 列

功 能 1 功 能 詳 見 下 列

功 能 2 功 能 詳 見 下 列 5ms 功 能

功 能 3 功 能 詳 見 下 列

功 能 詳 見 下 列

1

&038; 2 utilipower &038;

500VA	
350W	
700W	
12V 24V	
PWM	12V 24V
	10A
	12V 25V 24V 50V
335 * 165 * 375	
355 * 185 * 395	
7	
8	
1	
	2
	3
AC	220V 35± 110V + 35
	3±50Hz 60Hz±3
AC	3±220V 230V±3 or 240V±3 100V±3 110V±3
	0.5±50Hz 60Hz±0.5
AC	0 15A
PV PWM	
	+ LED
THD≤3	
> 120 1 > 130 10S	
	1 6W
	1 3 a
90 80	
<5ms DC / DC AC AC	
	-10°C 50°C
	90 10
	≤4000m

- " "

- 038; OEM
-

□□

I-P-SPC-Series System



□□

□□□□□□□□□□□□□□□□□□□□

□□□□2014□5□5□□□1□□□□□□□□