

LCD

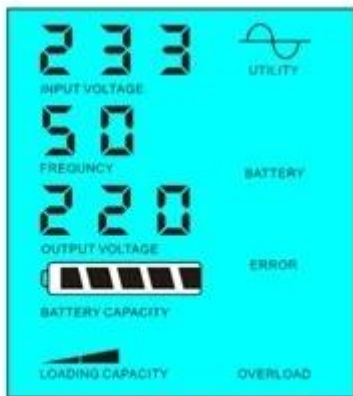

Utility supply power and charge battery

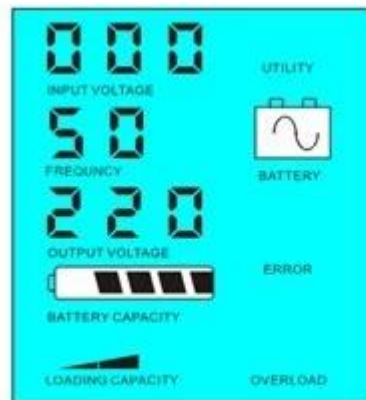

Without utility and battery supply power

2.2 UPS 03

1

2

3

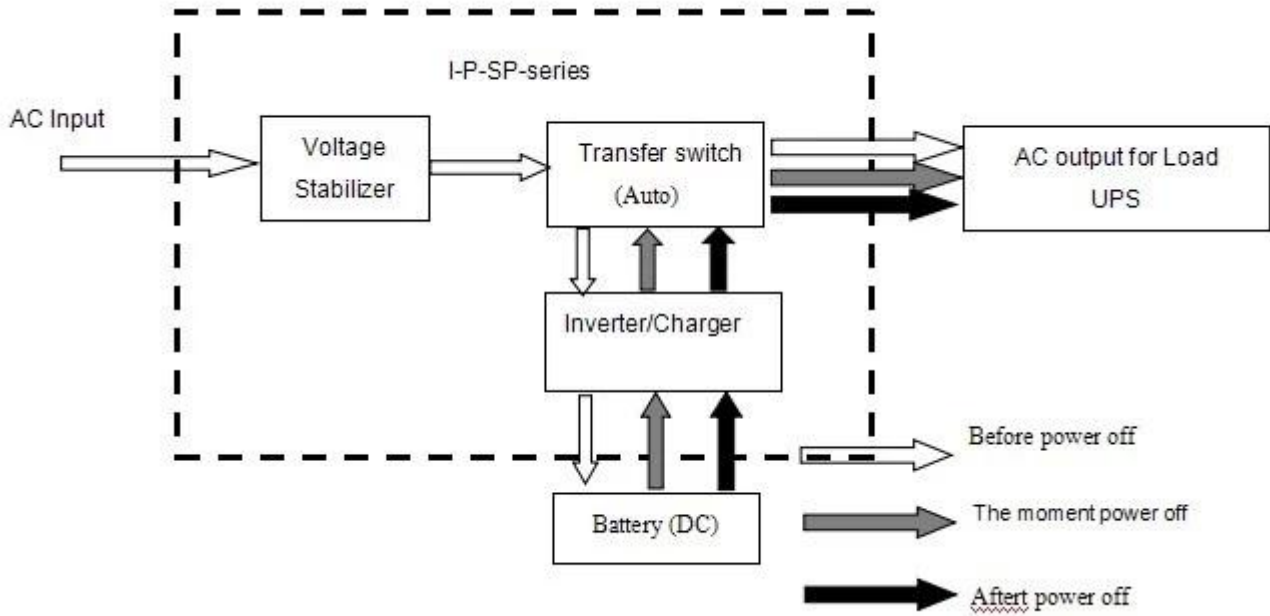

LCD

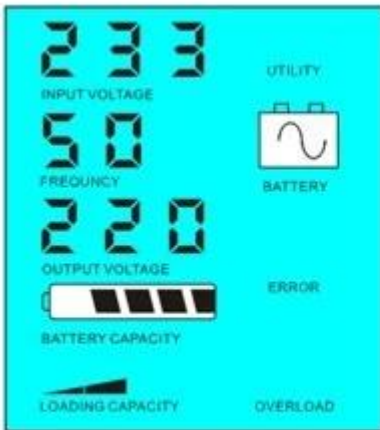

Battery has power

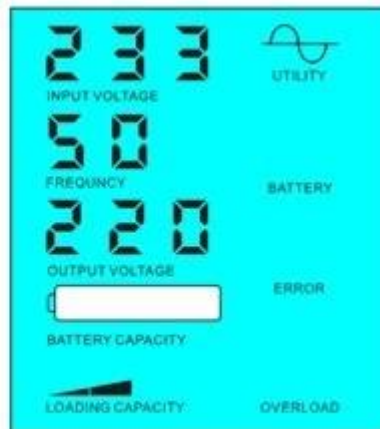

Battery dead, utility supply power

	500VA	700VA	1000VA	1500VA	2000VA	3000VA	4000VA
--	-------	-------	--------	--------	--------	--------	--------

