

## Features

1. Pure sine wave output.
2. CPU management, intelligent control, modular design.
3. LCD and LED display. can visually display all working parameters and status such as input voltage, output voltage, output frequency, battery capacity, load condition, status information, etc.
4. Sleep mode and normal working mode. the output priority (AC first or DC first) and the output frequency (50 HZ or 60 HZ) can be set to satisfy user with different using environment.
5. High conversion efficiency (87%-98%), low power consumption (1W~6W under sleep mode). It is the best choice of inverters for solar power system.
6. 8 kinds of batteries can be charged on global market, such as sealed lead acid battery, open lead- acid battery, gel battery, etc. Kindly note that to charge lithium battery, the related parameters need to be set in factory.
7. High charging power and the charging function can be closed
8. This series of inverters have strong load-carrying ability and overload capacity. The peak power is 3 times of the rated output power. For example, 1KW rated power inverter can carry 1HP air conditioner, and 2KW for 2HP, 3KW for 3HP, etc.
9. Adopting the latest American low frequency circuit design, brand new imported electric materials, pure copper transformer, the system is very stable, and has low malfunction rate, long service life (more than 5 years under normal use)
10. Perfect protection (low voltage protection, over voltage protection, overheats protection, short-circuit protection, overloads protection)
11. EMC, LVD, RoHS approvals
12. 2-year warranty and life-long technical support

## Application

1. Back-up UPS and EPS system for military, industrial, commercial, household, etc..
2. Mobile power and standby power for areas that are lack of utility
3. Off-grid solar & wind power system
  - 3.1. Simple Off-grid solar & wind power system
  - 3.2. AC first Off-grid solar & wind power system
  - 3.3. DC first Off-grid solar & wind power system

In all the above application fields, this series of inverter is suitable for all kinds of inductive loads, capacitive load and resistive load such as air conditioner, refrigerator, washing machine, TV, etc.

Function

## 1. Inversion function

Can be set to normal working mode (press the button to "ON") and sleep mode (press the button to "S-ON")

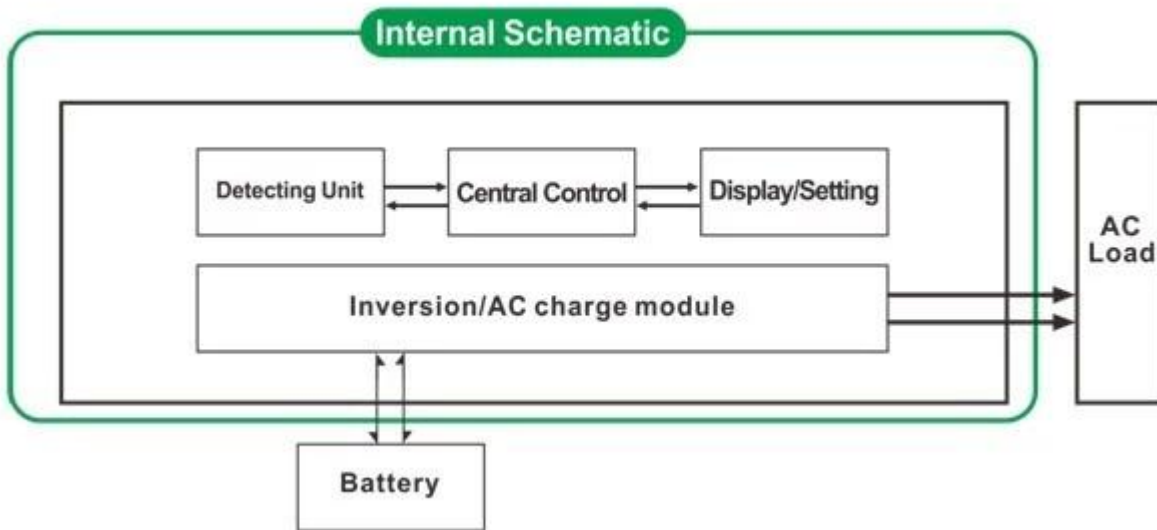

### 1.1 Normal working mode (ON): No matter whether there are AC loads

connected to the inverter or not, the output terminal of inverter will always have voltage ready to supply power to the loads. Under this mode, the power consumption is a little higher and the LCD will display the output voltage.

1.2 Sleep mode (S-ON): If the power of the loads that connected to the inverter is lower than 30W, there will be no output from the inverter. That is to say, only the chip of inverter is working under such condition and the power consumption is only 1-6W; If the power of the loads that connected to the inverter is more than 30W, then the inverter will automatically start the inversion function and supply power to the loads within 5s. The LCD will display no output.

## 2. High-power intelligent charging function

Can charge 8 kinds of conventional batteries on global market (refer to the parameter for more details)

Great charging power (refer to the parameter for more details)

Three-stage charging mode: Constant current charging stage (CC), Constant voltage charging stage (CV), Float charging stage (CF)



PS: when the battery type is set to “0”, it will not charge the battery and charging current is “0”. Also the charging indicator will not light.

### 3. UPS function

Can be set as utility first, battery standby mode and battery first, utility standby mode.

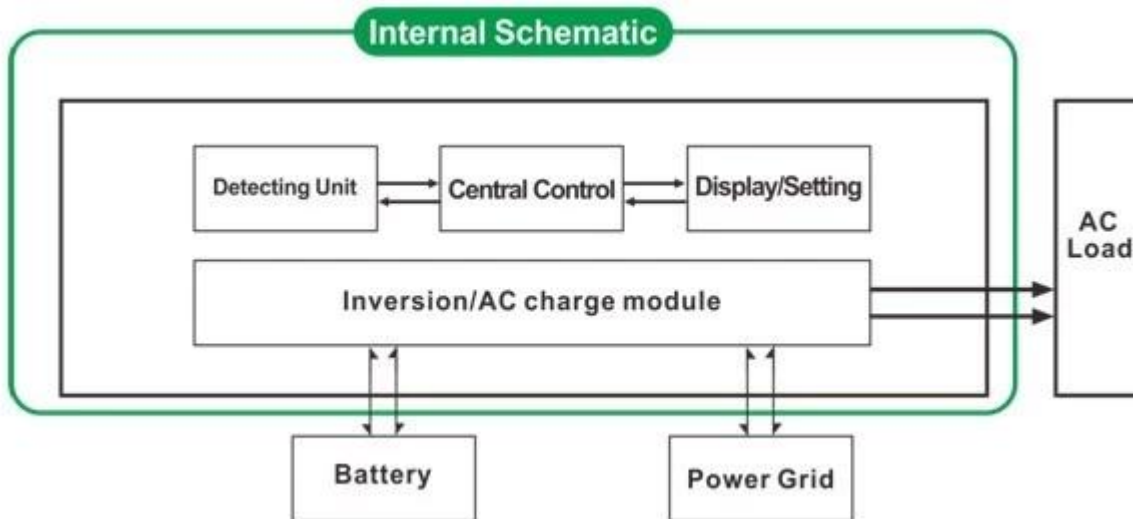

#### 3.1. Utility first, battery standby UPS mode (press the button to “AC”)

When both utility and battery are connected to the inverter, utility will supply power to the loads prior to the battery. When utility is cut off, the battery will automatically continue to supply power after inversion.

Steps are as follows:

Step 1: When utility power is available, it will output directly and charge batteries at the same time (can set battery type)

Step 2: When utility power is cut off suddenly, the inverter will convert DC power (battery) to AC power automatically to ensure uninterrupted power supply within 5ms.

Step 3: When utility power becomes available again, it will automatically transfer to utility supplying power to loads and charge batteries at the same time ((can set battery type)

See Workflow as below.

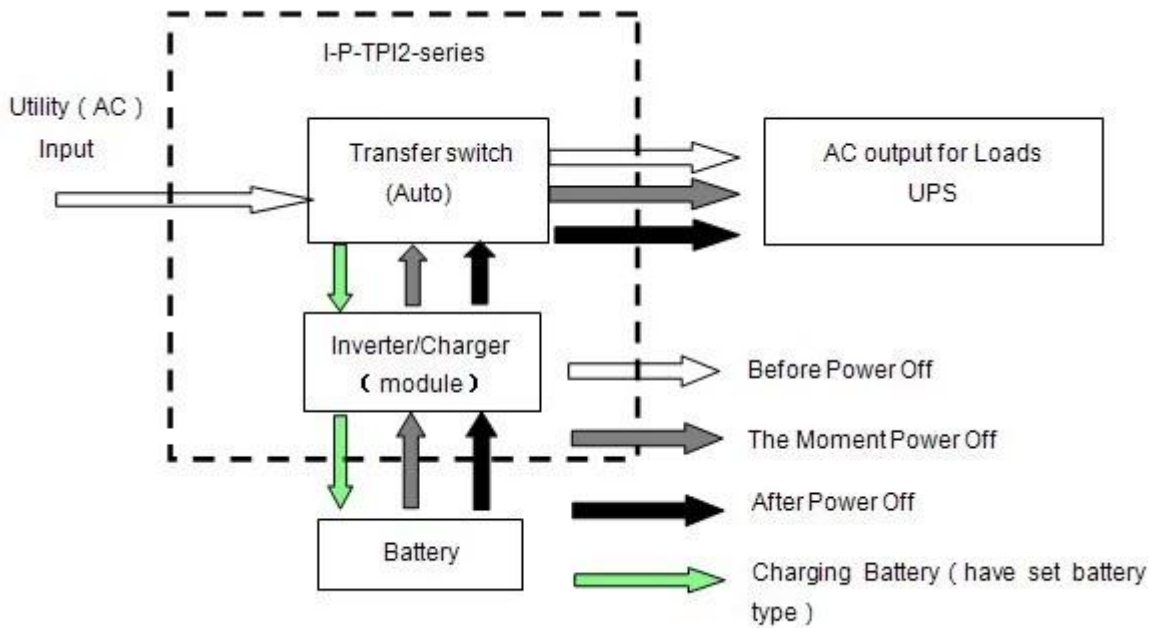

### 3.2. Battery first, utility standby UPS mode (press the button to “DC”).

Under this mode, it will not charge the battery and the “battery type” need to set to “0”

When both utility and battery are connected to the inverter, battery will supply power to the loads prior to utility. When battery capacity is not

enough, utility will continue to supply power automatically.

Steps are as follows:

Step 1: When battery has enough power, it will supply power to the loads directly

Step 2: When battery does not have enough power, it will automatically transfer to utility supplying power to the loads

Step 3: After the battery is fully charged (e.g. by solar or wind charge controller), it will then automatically transfer to battery supplying power to the loads.

See Workflow as below.

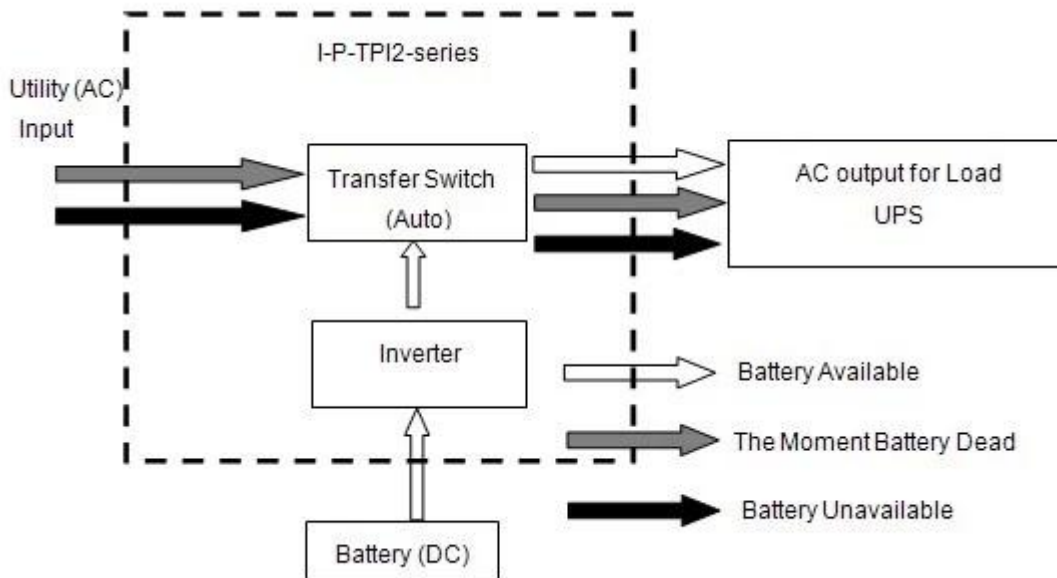

## Parameter

Parameter		Model	1000W	2000W	3000W	4000W	5000W	6000W	
Rated Output Power			1000W	2000W	3000W	4000W	5000W	6000W	
Peak Power			3000W	6000W	9000W	12000W	15000W	18000W	
Battery Voltage(DC)			12V or 24V or 48V [optional]			24V or 48V [optional]			
Size WxDxH(mm)			318*218*368			440*218*400			
Packing Size WxDxH(mm)			395*275*520			520*275*520			
Net Weight (kg)			27	28	30	39	40	51	
Gross Weight (kg)			29	30	32	43	48	53	
Working Mode [Setting]	ON		Normal working mode						
	S-ON		Sleep Mode, no utility, load's power higher than 30 W, start to work automatically						
	OFF		Completely off						
AC Input	Voltage		220V±35% or 110V±35% [optional]						
	Frequency		Decided by nationality, 50HZ or 60HZ						
AC Output	Voltage		220V±3% or 230V±3 or 240V±3% or 100V±3% or 110V±3% [optional]						
	Frequency		Under utility mode [frequency is the same as Under battery mode] 50Hz or 60Hz [optional]						
Utility Charging [Battery type "0" means charging function is closed]	AC	BAT	1000W	2000W	3000W	4000W	5000W	6000W	
	Charge Current [MAX]	12V	35A	65A	75A	/	/	/	
		24V	20A	35A	45A	65A	70A	75A	
		48V	10A	15A	30A	35A	40A	50A	
	Battery Type			American gel battery, Wool battery 1, Wool battery2, Sealed Lead Acid Battery, Europe gel battery, Open lead-acid batteries, Calcium Battery, De-Acid Battery or OEM Battery					
	Charging Mode			Three-stage charging: CC, CV, CF.					
	Charging Time			Decided by battery capacity and quantity					
Battery Protection			Automatic detection, charge and discharge protection, intelligent management						
UPS Priority	AC		Utility first, battery standby						
	DC		Battery first, utility standby						
Display	Display Mode		LCD+LED						
	Display Information		Input voltage, output voltage, output frequency, battery capacity, Load condition, Status Information						

Output Wave Type		Pure sine wave
Overload Ability		□120% 1 min, □130% 10s
Power Consumption	Sleep Mode	1~6W
	Normal Mode	1~3A
Conversion Efficiency		80%~90%
Transfer Time		□5ms □AC to DC / DC to AC□
Protection		Overload output, short-circuit, high-voltage input, low-voltage input, overheats
Environment	Temperature	-10°C□50°C
	Humidity	10%□90%
	Altitude	≤4000m

The above is our standard parameter. Subject to change without prior notice.

We have our own professional inverter and controller R&D team and we provide technical support and OEM service.

## **Others**

Please refer to the outline design, technical documents, product brochures, etc.

Made by Engineering Department, May 13, 2014, 2nd Edition