

Features

- 1) Easy to install. To configure a solar system, customers only need to connect it with solar panels and batteries.
- 2) CPU management and control, modular design
- 3) LCD display, can visually display various parameters (such as the output voltage, frequency, working mode, etc)
- 4) Multifunction design, customers don't need to buy solar, controller, charger and stabilizer, etc
- 5) External battery connection, convenient to expand back-up power time; user can connect as many batteries as needed according to the local sunlight and wind.
- 6) With superload-carrying ability and high load capacity, this series of inverters can not only drive resistance load; but also various kinds of inductive loads, such as motor, air conditioner, electric drills, fluorescent lamp, gas lamp, etc. It can drive almost any kind of load
- 7) Low frequency pure sine wave circuit design, good system stability, easy for maintenance, low failure rate and long service life (under proper operation, it may be as long as 5 years)
- 8) Perfect protection: low voltage protection, over voltage protection, overheat protection, short-circuit protection, overloads protection
- 9) CE / EMC / LVD/RoHS /CCC approvals
- 10) 2 years warranty, life-long technical supports

Function

1. Sole inversion function under inversion mode only connected to battery, can be set to normal working mode and sleep mode

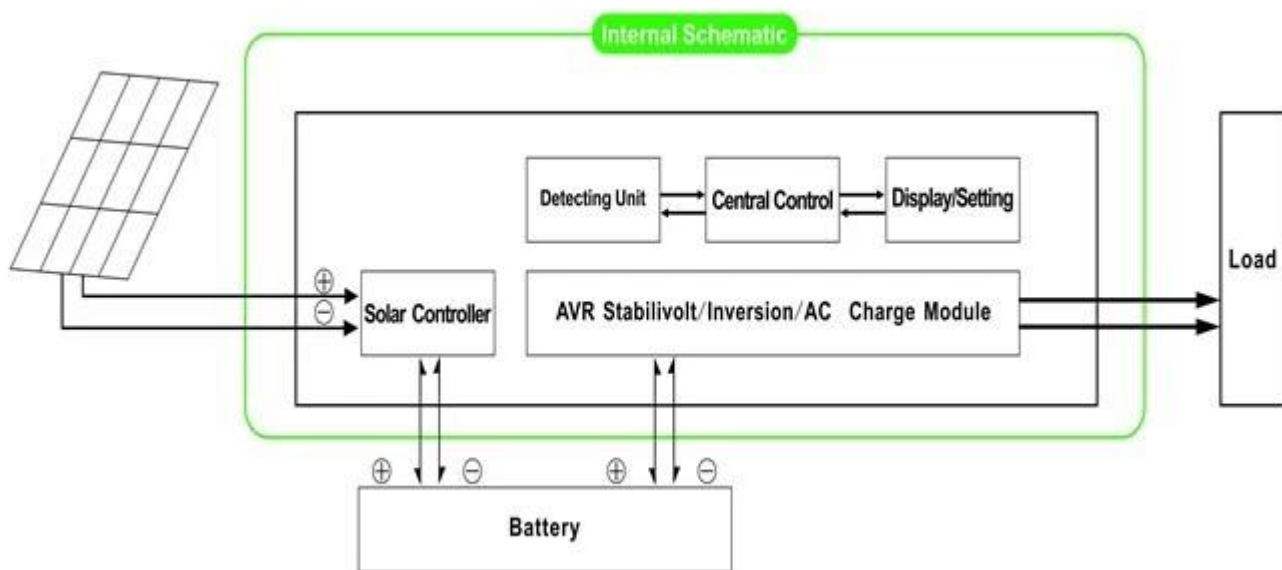

1.1 Normal working mode □ FREQUENCY in the LCD display is set as 01. No matter whether there are AC loads connected to the inverter or not, the inverter's output terminal will always have voltage ready to supply power to the loads. Under this mode, the LCD will be displayed as bellow:

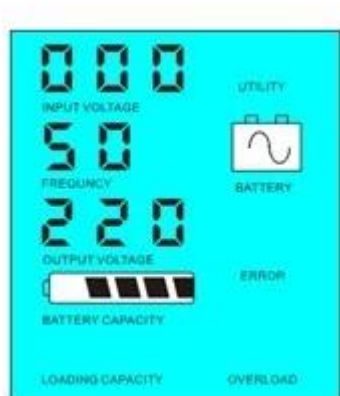

1.2 Sleep mode □ FREQUENCY in the LCD display is set as 02. If the power of the loads that connected to the inverter is lower than 5% of the inverter's rated power, there will be no output from the inverter. That is to say, only the chip of inverter is working under such condition and the power consumption is only 1-6W; If the power of the loads that connected to the inverter is higher than 5% of the inverter's rated power, then the inverter will automatically start the inversion function and supply power to the loads within 5s. As shown below:

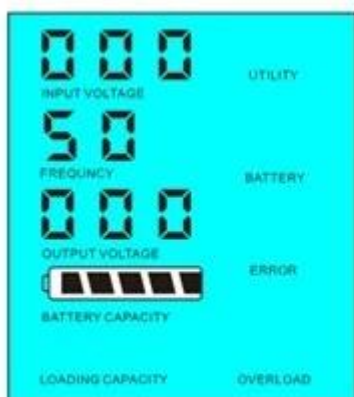

Load's power < 5% of inverter's rated power



Load's power > 5% of inverter's rated power

System introduction under this mode:

- 1) Only the solar panel charges the battery
- 2) Independent sole off-grid solar power system; suitable for areas that are lack of utility or have rich solar energy

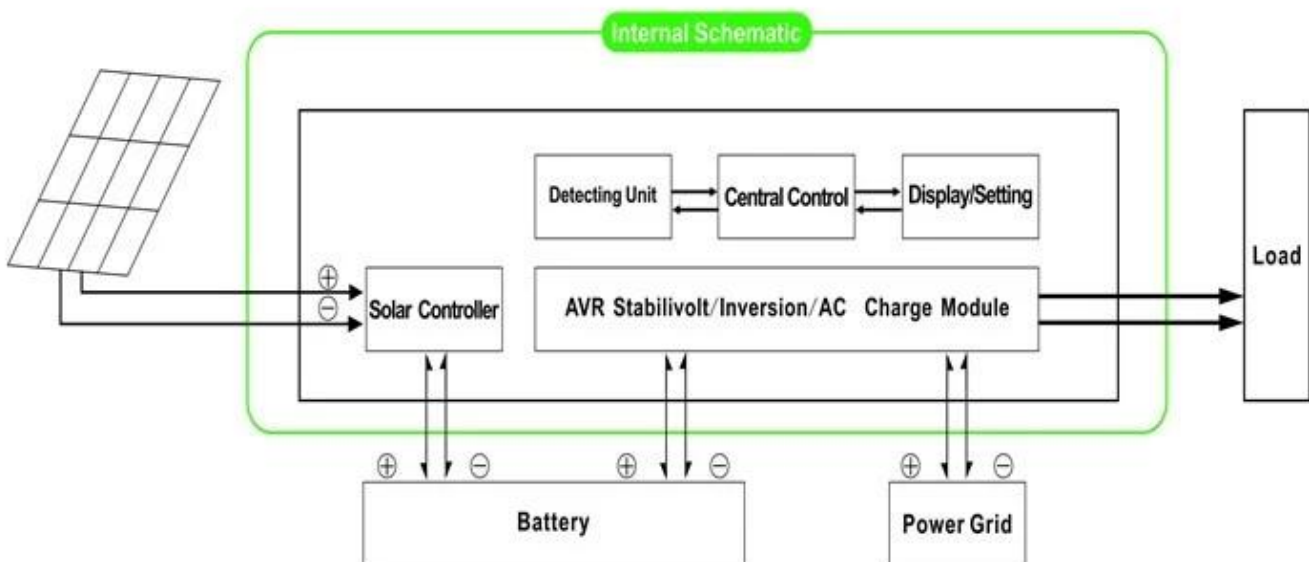

2. UPS function under utility mode □ connected to battery and utility .Can be set as utility first, battery standby mode and battery first, utility standby mode.

2.1. Utility first,battery standby UPS mode: FREQUENCY in the LCD display is set as 01. When both utility and battery are connected to the inverter, utility will supply power to the loads prior to the battery. When utility is cut off, the battery will automatically continue to supply power after inversion.

Steps are as follows:

Step 1: When utility power is available, it will output directly after voltage being stabilized and charge batteries at the same time.

Step 2: When utility power is cut off suddenly, the inverter will convert DC power to AC power automatically to ensure uninterrupted power supply within 5ms.

Step 3: When utility power becomes available again, it will automatically transfer to utility supplying power to loads and charge batteries at the same time.

See Workflows below:

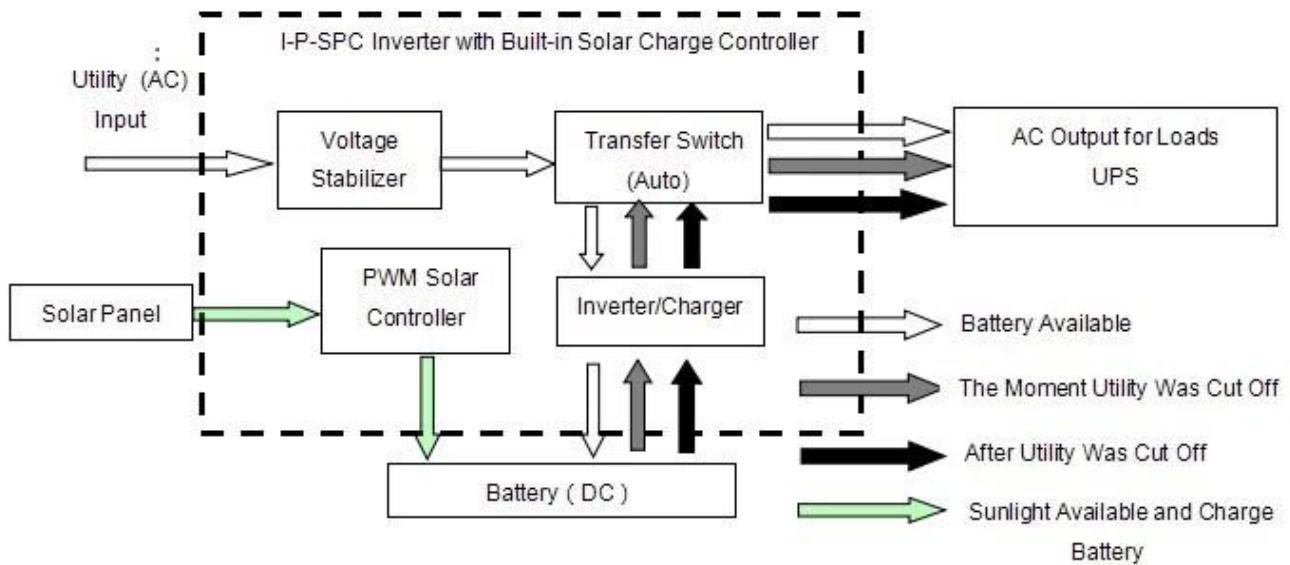

LCD displayed as bellow:

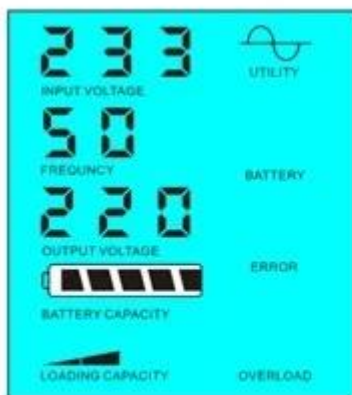

Utility supply power and charge battery

Without utility and battery supply power

System introduction under this mode:

- 1) There are 2 ways to charge the battery, utility and solar panel
- 2) This system is suitable for power systems built in areas lacking utility or power systems that frequently used in areas with/without utility

2.2. Battery first, utility standby UPS mode: FREQUENCY in the LCD display is set as 03. When both utility and battery are connected to the inverter, battery will supply power to the loads prior to utility. When battery capacity is not enough, utility will continue to supply power automatically.

Steps are as follows:

Step 1: When battery has enough power, it will supply power to the loads directly

Step 2: When battery does not have enough power, it will automatically transfer to utility supplying power to the loads

Step 3: After the battery is fully charged (e.g. by solar or wind charge controller), it will then automatically transfer to battery supplying power to the loads.

See Workflows below:

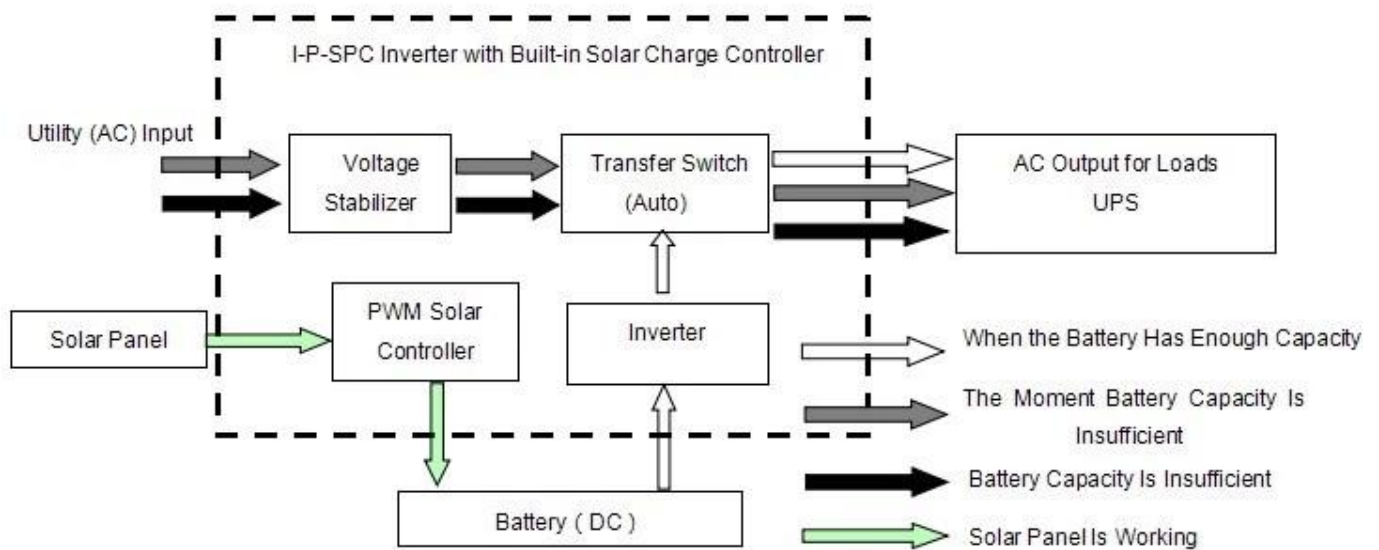

LCD displayed as bellow:

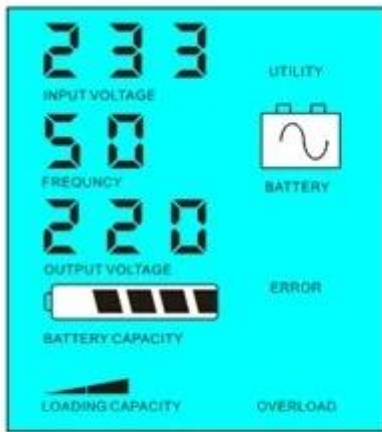

Battery has power and supply power

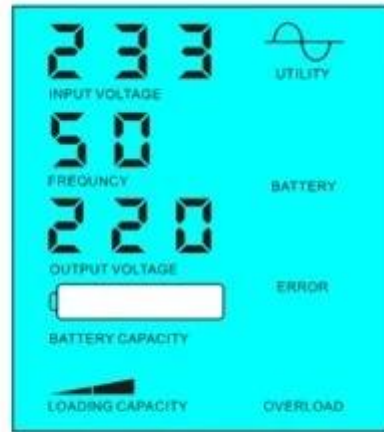

Battery dead, utility supply power

System introduction under this mode:

1) There is only way to charge the battery: solar panel

2) This system is suitable for areas where electricity is expensive and environmental areas where solar power can be fully used to save utility power, such as family solar & wind system and street light solar & wind system

Parameter

Parameter	500VA		700VA		1000VA	1500VA	2000VA		3000VA	4000VA
Rated Output Capacity	350W		500W		700W	1000W	1500W		2000W	3000W
Peak Power	700W		1000W		1500W	2000W	3000W		4000W	6000W
Battery Voltage(DC)	12V or 24V				24V	24V or 48V				
PWM Solar Controller	Voltage	12V or 24V				24V	24V or 48V			
	Current	10A	20A		20A	30A		40A		
	PV Max Input Voltage	12V System 25V 24V System 50V				50V	24V System 50V 48V System 100V			
Size WxDxH(mm)	335*165*375				350*220*460					
Packing Size WxDxH(mm)	355*185*395				370*240*480					
Net Weight (kg)	7	8	12	14	20	23	29			
Gross Weight (kg)	8	9	13	16	22	25	31			

Model Parameter	5000VA	6000VA	7000VA	10kVA	15kVA	20kVA	30kVA	
Rated Output Capacity	3500W	4000W	5000W	7000W	10000W	15000W	20000W	
Peak Power	7000W	8000W	10000W	14000W	20000W	30000W	40000W	
Battery Voltage(DC)	48V				96V	192V		
PWM Solar Controller	Voltage	48V				96V	192V	
	Current	50A	60A	50A		50A		
	PV Max Input Voltage	100V		200V		400V		
Size WxDxH(mm)	420*260*605				420*280*625			
Packing Size WxDxH(mm)	440*280*625				440*300*645			
Net Weight (kg)	31	50	50	55	85	105	125	
Gross Weight (kg)	33	55	60	65	95	115	135	

General Parameter		
Working mode (setting)	01	Utility First, Battery Standby
	02	Sleep Mode, no utility, load's power higher than 5% of rated power, start to work automatically
	03	Battery first, utility standby

AC Input	Voltage	220V±35% or 110V+35%□Optional□
	Frequency	50Hz±3% or 60Hz±3% □Optional□
AC Output	Voltage	220V±3% or 230V±3 or 240V±3% or 100V±3% or 110V±3% (Optional)
	Frequency	50Hz±0.5 or 60Hz±0.5 (Optional)
Utility charge	AC Charge Current	0~15A
	Charge Time	Depend on battery capacity and quantity
	Battery Protection	Automatic detection, Charge and discharge protection,Intelligent Management
PV Charge		Total Current of PV Input Should Be Less Than Rated Current
Display	Display Mode	LCD+LED
	Display Information	Input voltage,output voltage,output frequency,battery capacity,Load condition,Status Information
Output Wave Type		Pure sine wave output,waveform distortion rate≤3
Overload Ability		□120% 1 min,□130% 10s
Power Consumption	Sleep Mode	1~6W
	Normal Mode	1~3A
Conversion Efficiency		80%~90%
Transfer Time		□5ms □AC to DC / DC to AC□
Protection		Overload output,short-circuit,high-voltage input,low-voltage input,overheat
Environment	Temperature	-10°C□50°C
	Humidity	10%□90%
	Altitude	≤4000m

- The above parameters with “or” means that the parameter needs to do factory settings as per customer’s preference.
- We have our own professional inverter controller and UPS R&D team and we provide technical support and OEM service.
- The controller information above is our company’s standard parameter can be changed according to customer’s requirement.

ConnectionDiagram

I-P-SPC-Series System



I-P-HPC-Series Inverter+Solar Controller

Others

Please refer to the outline design, technical documents, product brochures, etc.

Made by Engineering Department, May 5, 2014, 1st Edition